

# *Installation Planning Guide*

*Varian, Inc. NMR Systems*

*Pub. No. 01-999262-00, Rev. A0305*



**VARIAN**

# ***Installation Planning Guide***

*Varian, Inc. NMR Systems*

*Pub. No. 01-999262-00, Rev. A0305*



**VARIAN**

*Installation Planning*  
NMR Spectrometer Systems  
Pub. No. 01-999262-00, Rev. A0305

Revision history:  
A0305 – Initial issue

Technical contributors: Mark Stevenson, Mark Van Crielkinge, Andy Myles, Tim Luca  
Technical Writer: Mike Miller  
Technical Editor: Dan Steele

Copyright ©2005 by Varian, Inc.  
3120 Hansen Way, Palo Alto, California 94304  
<http://www.varianinc.com>  
1-800-356-4437

All rights reserved. Printed in the United States.

The information in this document has been carefully checked and is believed to be entirely reliable. However, no responsibility is assumed for inaccuracies. Statements in this document are not intended to create any warranty, expressed or implied. Specifications and performance characteristics of the software described in this manual may be changed at any time without notice. Varian reserves the right to make changes in any products herein to improve reliability, function, or design. Varian does not assume any liability arising out of the application or use of any product or circuit described herein; neither does it convey any license under its patent rights nor the rights of others. Inclusion in this document does not imply that any particular feature is standard on the instrument.

Varian, Inc. product names are trademarks or registered trademarks of Varian, Inc. Sun and the Sun logo are trademarks of Sun Microsystems, Inc. SPARC and SPARCstation are trademarks of SPARC International. Tygon is a trademark of DuPont Company. Ethernet is a trademark of Xerox Corporation. Oxford is a registered trademark of Oxford Instruments, Ltd. Other product names are trademarks or registered trademarks of their respective holders.

# Table of Contents

<b>SAFETY PRECAUTIONS</b> .....	<b>9</b>
<b>Introduction</b> .....	<b>13</b>
<b>Chapter 1. Site Selection and System Delivery</b> .....	<b>17</b>
1.1 Installation Planning Process .....	17
1.2 Site Selection .....	18
1.3 Transport Route and System Shipping Dimensions .....	19
1.4 System Shipment .....	20
Selecting a Local Shipping Company .....	21
Postdelivery Inspection .....	21
<b>Chapter 2. Installation Site Requirements</b> .....	<b>23</b>
2.1 Accessibility of Site .....	23
2.2 Site Size .....	23
2.3 Ceiling Height Requirements .....	25
2.4 Structural Strength of Floor .....	26
Magnet Weight Distribution, With No Antivibration System .....	26
Magnet Weight Distribution, With Antivibration System .....	27
2.5 Floor Vibration Requirements .....	29
2.6 Magnet Support Requirement .....	29
2.7 Magnetic Environment .....	30
2.8 Ventilation .....	32
2.9 Ambient Temperature and Humidity .....	32
2.10 Radio-Frequency Environment .....	33
Radio-Frequency Interference .....	33
Radio-Frequency Emissions from Varian NMR Equipment .....	34
2.11 Site Altitude and Manostat Pressure Setting .....	36
<b>Chapter 3. Site Preparation</b> .....	<b>37</b>
3.1 Line Voltage Variation .....	37
3.2 Uninterrupted Power Supply .....	38
3.3 Electrical Outlets .....	38
3.4 Separate Air Sources for System Options .....	40
3.5 Compressed Air Supply .....	41
3.6 Compressed Nitrogen Gas .....	42
3.7 Gas Supplies for Solids Systems .....	42
3.8 AC Power and Air Conditioning .....	43

3.9	Telephone and Internet Access .....	43
3.10	Electrostatic Discharges .....	45
3.11	Host Workstation Preparation .....	45
	Magnetic Field Considerations .....	45
	Required Peripherals .....	45
	Operating System Installation .....	45
	Collecting System and Network Information .....	46
<b>Chapter 4. Installation Supplies .....</b>		<b>49</b>
4.1	Required Installation Supplies and Equipment .....	49
	Liquid Helium Supply .....	50
	Liquid Nitrogen Supply .....	51
	Helium Gas Supply .....	51
	Nitrogen Gas Supply for Magnet Installation .....	51
	Face Mask and Thermal Gloves .....	52
	Heat Gun .....	52
	Nonferromagnetic Ladder .....	52
	Hoist .....	52
	Isopropyl Alcohol and Acetone Solvents .....	52
4.2	Recommended Installation Supplies and Equipment .....	53
	Cryogenic Equipment Rack .....	53
	Electrical Power Surge Protector .....	53
	Monitor Degaussing Coil .....	53
4.3	LC-NMR Equipment, Supplies, and Solvents .....	53
<b>Chapter 5. Stray Magnetic Fields .....</b>		<b>55</b>
5.1	Safety Hazards of Strong Magnetic Fields .....	55
	Pacemakers .....	55
	Magnetic Field Exposure .....	56
5.2	Stray Field Plots .....	57
5.3	Posting Requirements for Magnetic Field Warning Signs .....	71
	Warning Signs .....	71
<b>Chapter 6. System Cable Lengths and Room Layouts .....</b>		<b>73</b>
6.1	System Cable Lengths .....	73
	RF Cable Harness Between the Magnet RF Front End and Console .....	73
	Pneumatics Router .....	74
	Ethernet Cable Between Console and Host Computer .....	74
6.2	NMR Room Layouts .....	75
	Minimum Space for a 300/54 System Without Options .....	75
	Standard Space for a 300/54 System Without Options .....	76
	Recommended Space for a 300/54 System With Autosampler .....	77
	Minimum Space for a 300/89 System With Solids and Microimaging .....	78
	Standard Space for a 400/54 or 300/89 System Without Options .....	79
	Standard Space for a 400/54 or 500/51 System With Options .....	80
	Minimum Space for a 600/51 System .....	81

LC-NMR Minimum Room Layout .....	82
LC-NMR Suggested Room Layout 1 .....	83
LC-NMR Suggested Room Layout 2 .....	83
Illustrations for Room Layout .....	86
Blank Grid for Room Layout .....	87
<b>Index</b> .....	<b>89</b>

*Table of Contents*

# List of Tables

<b>Table 1.</b> Cabinet Dimensions as Shipped, with Crate and Pallet .....	19
<b>Table 2.</b> System Accessories Dimensions as Shipped with Crates and Pallets as Appropriate ....	19
<b>Table 3.</b> Magnet Dimensions as Shipped with Crate and Pallet .....	20
<b>Table 4.</b> Cabinets Dimensions and Weights .....	24
<b>Table 5.</b> Magnet Dimensions with Stand or Legs Attached .....	24
<b>Table 6.</b> System Accessories Dimensions and Weights .....	25
<b>Table 7.</b> Ceiling Minimum Height .....	26
<b>Table 8.</b> Interaction Between a Magnetic Field and Common Objects .....	31
<b>Table 8.</b> Interaction Between a Magnetic Field and Common Objects .....	31
<b>Table 9.</b> Liquid Helium Displacement for Room Ventilation Considerations .....	32
<b>Table 10.</b> Ambient Temperature and Relative Humidity .....	33
<b>Table 11.</b> Operating Frequencies for NMR Spectrometers .....	33
<b>Table 12.</b> Operating Frequencies for Common Nuclei .....	34
<b>Table 13.</b> IEEE/ANSI C95.1–1991 Standard for RF Radiation Levels .....	34
<b>Table 14.</b> Results of RF Emissions Tests on Varian NMR Equipment .....	35
<b>Table 15.</b> Electrical Outlets/Circuits Requirements .....	38
<b>Table 16.</b> Models of Highland L500 Gradient Amplifiers .....	40
<b>Table 17.</b> Compressed Air Supply Source .....	41
<b>Table 18.</b> Maximum Air Conditioning Requirements .....	44
<b>Table 19.</b> Preinstallation Worksheet OS Installation .....	46
<b>Table 20.</b> Initial Onsite and Short Notice Liquid Helium Supplies .....	50
<b>Table 21.</b> Initial Onsite Liquid Nitrogen Supply .....	51
<b>Table 22.</b> Helium Gas Supply .....	51
<b>Table 23.</b> Stray Field Data for Oxford Magnets .....	56
<b>Table 24.</b> Stray Field Data for NMR Magnet Systems .....	57
<b>Table 25.</b> Magnet Centerline to Floor .....	58

# List of Figures

<b>Figure 1.</b> Plan Views of Floor Contact Points of Magnet Stands .....	27
<b>Figure 2.</b> Platform Antivibration System Leg Placements and Sizes .....	27
<b>Figure 3.</b> Magnet Leg Antivibration Systems Leg Placement and Sizes .....	28
<b>Figure 4.</b> Magnet Leg Antivibration 900/54 System Leg Placement and Sizes .....	29
<b>Figure 5.</b> Typical Vertical Stray Fields for High-Field Magnets .....	31
<b>Figure 6.</b> Recommended Manostat Set Pressure as a Function of Altitude .....	36
<b>Figure 7.</b> Internal Wiring of Gradient Cabinet .....	40
<b>Figure 8.</b> Setup for Switching Gas Supplies .....	43
<b>Figure 9.</b> Stray Field Plots for 800/63 Magnets .....	69
<b>Figure 10.</b> 10-Gauss Warning Sign .....	72
<b>Figure 11.</b> 5-Gauss Warning Sign .....	72
<b>Figure 12.</b> Magnet Area Danger Sign .....	72
<b>Figure 13.</b> Cable Lengths for 200–500-MHz Systems without Options .....	73
<b>Figure 14.</b> Cable Lengths for High-Field Systems and Systems with Options .....	74

# SAFETY PRECAUTIONS

The following warning and caution notices illustrate the style used in Varian manuals for safety precaution notices and explain when each type is used:



This symbol might be used on warning labels attached to the equipment. When you see this symbol, refer to the relevant manual for the information referred to by the warning label.

**WARNING:** Warnings are used when failure to observe instructions or precautions could result in injury or death to humans or animals, or significant property damage.

**CAUTION:** Cautions are used when failure to observe instructions could result in serious damage to equipment or loss of data.

## Warning Notices

*Observe the following precautions during installation, operation, maintenance, and repair of the instrument. Failure to comply with these warnings, or with specific warnings elsewhere in Varian manuals, violates safety standards of design, manufacture, and intended use of the instrument. Varian assumes no liability for customer failure to comply with these precautions.*

**WARNING:** Persons with implanted or attached medical devices such as pacemakers and prosthetic parts must remain outside the 5-gauss perimeter from the centerline of the magnet.

The superconducting magnet system generates strong magnetic fields that can affect operation of some cardiac pacemakers or harm implanted or attached devices such as prosthetic parts and metal blood vessel clips and clamps.

Pacemaker wearers should consult the user manual provided by the pacemaker manufacturer or contact the pacemaker manufacturer to determine the effect on a specific pacemaker. Pacemaker wearers should also always notify their physician and discuss the health risks of being in proximity to magnetic fields. Wearers of metal prosthetics and implants should contact their physician to determine if a danger exists.

Refer to the manuals supplied with the magnet for the size of a typical 5-gauss stray field. This gauss level should be checked after the magnet is installed.

**WARNING:** Keep metal objects outside the 10-gauss perimeter from the centerline of the magnet.

The strong magnetic field surrounding the magnet attracts objects containing steel, iron, or other ferromagnetic materials, which includes most ordinary tools, electronic equipment, compressed gas cylinders, steel chairs, and steel carts. Unless restrained, such objects can suddenly fly towards the magnet, causing possible personal injury and extensive damage to the probe, dewar, and superconducting solenoid. The greater the mass of the object, the more the magnet attracts the object.

## SAFETY PRECAUTIONS

Only nonferromagnetic materials—plastics, aluminum, wood, nonmagnetic stainless steel, etc.—should be used in the area around the magnet. If an object is stuck to the magnet surface and cannot easily be removed by hand, contact Varian service for assistance.

Refer to the manuals supplied with the magnet for the size of a typical 10-gauss stray field. This gauss level should be checked after the magnet is installed.

**WARNING: Only qualified maintenance personnel shall remove equipment covers or make internal adjustments.**

Dangerous high voltages that can kill or injure exist inside the instrument. Before working inside a cabinet, turn off the main system power switch located on the back of the console.

**WARNING: Do not substitute parts or modify the instrument.**

Any unauthorized modification could injure personnel or damage equipment and potentially terminate the warranty agreements and/or service contract. Written authorization approved by a Varian, Inc. product manager is required to implement any changes to the hardware of a Varian NMR spectrometer. Maintain safety features by referring system service to a Varian service office.

**WARNING: Do not operate in the presence of flammable gases or fumes.**

Operation with flammable gases or fumes present creates the risk of injury or death from toxic fumes, explosion, or fire.

**WARNING: Leave area immediately in the event of a magnet quench.**

If the magnet dewar should quench (sudden appearance of gasses from the top of the dewar), leave the area immediately. Sudden release of helium or nitrogen gases can rapidly displace oxygen in an enclosed space creating a possibility of asphyxiation. Do not return until the oxygen level returns to normal.

**WARNING: Avoid helium or nitrogen contact with any part of the body.**

In contact with the body, helium and nitrogen can cause an injury similar to a burn. Never place your head over the helium and nitrogen exit tubes on top of the magnet. If helium or nitrogen contacts the body, seek immediate medical attention, especially if the skin is blistered or the eyes are affected.

**WARNING: Do not look down the upper barrel.**

Unless the probe is removed from the magnet, never look down the upper barrel. You could be injured by the sample tube as it ejects pneumatically from the probe.

**WARNING: Do not exceed the boiling or freezing point of a sample during variable temperature experiments.**

A sample tube subjected to a change in temperature can build up excessive pressure, which can break the sample tube glass and cause injury by flying glass and toxic materials. To avoid this hazard, establish the freezing and boiling point of a sample before doing a variable temperature experiment.

**WARNING: Support the magnet and prevent it from tipping over.**

The magnet dewar has a high center of gravity and could tip over in an earthquake or after being struck by a large object, injuring personnel and causing sudden, dangerous release of nitrogen and helium gasses from the dewar. Therefore, the magnet must be supported by at least one of two methods: with ropes suspended from the ceiling or with the antivibration legs bolted to the floor. Refer to the *Installation Planning Manual* for details.

**WARNING: Do not remove the relief valves on the vent tubes.**

The relief valves prevent air from entering the nitrogen and helium vent tubes. Air that enters the magnet contains moisture that can freeze, causing blockage of the vent tubes and possibly extensive damage to the magnet. It could also cause a sudden dangerous release of nitrogen and helium gases from the dewar. Except when transferring nitrogen or helium, be certain that the relief valves are secured on the vent tubes.

**WARNING: On magnets with removable quench tubes, keep the tubes in place except during helium servicing.**

On Varian 200- and 300-MHz 54-mm magnets only, the dewar includes removable helium vent tubes. If the magnet dewar should quench (sudden appearance of gases from the top of the dewar) and the vent tubes are not in place, the helium gas would be partially vented sideways, possibly injuring the skin and eyes of personnel beside the magnet. During helium servicing, when the tubes must be removed, follow carefully the instructions and safety precautions given in the manual supplied with the magnet.

## Caution Notices

*Observe the following precautions during installation, operation, maintenance, and repair of the instrument. Failure to comply with these cautions, or with specific cautions elsewhere in Varian manuals, violates safety standards of design, manufacture, and intended use of the instrument. Varian assumes no liability for customer failure to comply with these precautions.*

**CAUTION: Keep magnetic media, ATM and credit cards, and watches outside the 5-gauss perimeter from the centerline of the magnet.**

The strong magnetic field surrounding a superconducting magnet can erase magnetic media such as floppy disks and tapes. The field can also damage the strip of magnetic media found on credit cards, automatic teller machine (ATM) cards, and similar plastic cards. Many wrist and pocket watches are also susceptible to damage from intense magnetism.

Refer to the manuals supplied with the magnet for the size of a typical 5-gauss stray field. This gauss level should be checked after the magnet is installed.

**CAUTION: Keep the PCs, (including the LC STAR workstation) beyond the 5-gauss perimeter of the magnet.**

Avoid equipment damage or data loss by keeping PCs (including the LC workstation PC) well away from the magnet. Generally, keep the PC beyond

the 5-gauss perimeter of the magnet. Refer to the *Installation Planning Guide* for magnet field plots.

**CAUTION: Check helium and nitrogen gas flowmeters daily.**

Record the readings to establish the operating level. The readings will vary somewhat because of changes in barometric pressure from weather fronts. If the readings for either gas should change abruptly, contact qualified maintenance personnel. Failure to correct the cause of abnormal readings could result in extensive equipment damage.

**CAUTION: Never operate solids high-power amplifiers with liquids probes.**

On systems with solids high-power amplifiers, never operate the amplifiers with a liquids probe. The high power available from these amplifiers will destroy liquids probes. Use the appropriate high-power probe with the high-power amplifier.

**CAUTION: Take electrostatic discharge (ESD) precautions to avoid damage to sensitive electronic components.**

Wear grounded antistatic wristband or equivalent before touching any parts inside the doors and covers of the spectrometer system. Also, take ESD precautions when working near the exposed cable connectors on the back of the console.

## Radio-Frequency Emission Regulations

The covers on the instrument form a barrier to radio-frequency (rf) energy. Removing any of the covers or modifying the instrument may lead to increased susceptibility to rf interference within the instrument and may increase the rf energy transmitted by the instrument in violation of regulations covering rf emissions. It is the operator's responsibility to maintain the instrument in a condition that does not violate rf emission requirements.

# Introduction

This guide assists in selecting and preparing a site to install a Varian NMR superconducting spectrometer system, including preparing the Sun workstation. Using the predelivery and postdelivery checklists provided and following the information presented should bring about a smooth transition from delivery to installation.

This guide contains the following chapters:

- **Chapter 1, “Site Selection and System Delivery,”** describes how to plan for the installation of an NMR spectrometer. This chapter also discusses system delivery and provides a table of shipping dimensions for NMR components. Begin in this chapter.
- **Chapter 2, “Installation Site Requirements,”** lists the factors to consider when selecting the installation site.
- **Chapter 3, “Site Preparation,”** describes the many factors to consider—electrical, cooling, safety, supplies, and so forth—when preparing the installation site.
- **Chapter 4, “Installation Supplies,”** describes the supplies required and recommended for the system installation.
- **Chapter 5, “Stray Magnetic Fields,”** provides magnetic field safety data and shows stray field plots for each magnet system.
- **Chapter 6, “System Cable Lengths and Room Layouts,”** provides information for laying out the NMR room.



## Importance of Communication

In planning the system installation, good communications are essential between the customer, the facility planner or architect, and Varian on a frequent basis. Any questions or problems must be addressed immediately to avoid delays and additional costs. One person from the customer's institution should be appointed to coordinate site planning and preparation. This person should represent all users of the system in dealing with Varian and the facility planner or architect.

## Contacting Varian

Varian's staff of thoroughly trained service specialists throughout the world is your assurance of always receiving prompt attention. For product sales and service information, contact one of the Varian sales offices:

- Argentina, Buenos Aires, (114) 783-5306
- Australia, Mulgrave, Victoria, (3) 9566-1138
- Austria, Vösendorf, (1) 699 96 69
- Belgium, Brussels, (02) 721 51 51
- Brazil, Sao Paulo, (11) 829-5444
- Canada, Ottawa, Ontario, (613) 260-0331
- China, Beijing, (10) 6846-3640
- Denmark, Herlev, (42) 84 6166
- France, Orsay, +33 (0)1 69 86 38 67
- Germany, Darmstadt, (6151) 70 30
- Italy, Milan, (+39) 02 9273401
- Japan, Tokyo, (3) 5232 1211
- Korea, Seoul, (2) 3452-2452
- Mexico, Mexico City, (5) 523-9465
- Netherlands, Houten, (0118) 61 71 56
- Norway, Oslo, (9) 86 74 70
- Russian Federation, Moscow, (95) 241-7014
- Spain, Madrid, (91) 472-7612
- Sweden, Solna, (8) 445 1601
- Switzerland, Zug, (41) 749 88 44
- Taiwan, Taipei, (2) 2698-9555
- United Kingdom, Oxford, England  
Sales and Service +44(1865) 388 883  
E- mail [technical.support@varianinc.com](mailto:technical.support@varianinc.com)  
NMR Service Manager, Europe and Pacific Rim
- United States, Palo Alto, California,  
Varian, Inc., NMR Systems  
Customer Sales Support, (650) 424-5434  
Service Support, Palo Alto, California, **1 (800) 356-4437**  
E- mail: [nmr.customersupport@varianinc.com](mailto:nmr.customersupport@varianinc.com)  
North American Service Manager  
9017 Mendenhall Ct., Ste D, Columbia, MD 21045  
(410) 381-7229

- Venezuela, Valencia (41) 257608

We at Varian will make every effort to ensure that the ownership of your new NMR spectrometer is a lasting and pleasurable experience.



## Chapter 1. Site Selection and System Delivery

Sections in this chapter:

- 1.1 “Installation Planning Process” [this page](#)
- 1.2 “Site Selection” [page 18](#)
- 1.3 “Transport Route and System Shipping Dimensions” [page 19](#)
- 1.4 “System Shipment” [page 20](#)

Varian’s delivery responsibility ends at the Varian factory shipping dock or at the customer’s receiving dock, depending upon the type of insurance obtained by the customer. In either case, for 200- through 600-MHz magnets, the customer must provide a moving crew to move the shipping crates holding the system from the delivery truck (or storage location) to the installation site. For 750-MHz magnets and larger, Varian provides a moving crew.

### 1.1 Installation Planning Process

Use the following steps to prepare for delivery of the system. Refer to the chapters in this guide for further details. Consult knowledgeable individuals, such as plant facilities personnel, for assistance in implementing these instructions.

1. Check the “SHIP BY” date on the Varian Order Acknowledgment form. Use this date as a target for completing installation preparations. If you anticipate any delays in site readiness and need to delay shipment, notify the factory at *least* 90 days in advance. Select the site for installing and operating the system. (Note: a site survey is standard with many spectrometer systems.)

Review the considerations described in [Section 1.2 on page 18](#) and make sure the site conforms to the requirements listed in [Chapter 2, “Installation Site Requirements,” on page 23](#).

2. Prepare the installation site, including electrical outlets, compressed air supply, and air conditioning as described in [Chapter 3, “Site Preparation,” on page 37](#). Make any computer preparations required, also described in [Chapter 3](#).
3. Order supplies and equipment for installation and startup operation, as described in [Chapter 4, “Installation Supplies,” on page 49](#).
4. Make arrangements for workers and equipment to move the system upon delivery to the installation site, as described in [Section 1.4, “System Shipment,” on page 20](#).
5. Read carefully, sign, and mail to Varian the “Object Code License Form.” (Note that acceptance of the products on the Order Acknowledgment form constitutes acceptance of the terms stated in the Object Code License Form, whether the form is signed or not.)

## 1.2 Site Selection

Site selection is the process of finding a location for the magnet providing the least interference with the building it occupies. The selection of an optimum site is determined almost entirely by the high magnetic fringe field of the system. The process of selection can be complex because of the interaction of the magnetic field with the surrounding environment. [Chapter 2, “Installation Site Requirements,”](#) describes in detail all the factors to consider when selecting a site.

1. Begin by looking for a site with a series of general requirements in mind. The placement of the magnet is the primary consideration:
  - How will the field from the affect its neighbors?
  - What will the building and its contents do to the quality of the magnet field?
  - Can the system be delivered to the site?
2. The second requirement is access:
  - Will the site limit public access in surrounding areas?
  - Can magnetic storage media be taken to the area safely?
  - Can cryogen transfers be made quickly and safely?
3. Finally, look at the area as a whole with the following considerations:
  - Look for an area large enough to contain the magnet and as much of the 5-gauss line as possible. The area should have the minimum ceiling height described in [Section 2.3, “Ceiling Height Requirements,”](#) on page 25.
  - When an acceptable space has been found, look for steel and iron in the immediate area. Consider the structural steel of the building, iron pipes, machinery, etc.
  - Look in the near area for elevators, vehicular traffic, large transformers, and other large amounts of steel and iron.
  - Consider the ability to control the movement of ferromagnetic objects, such as elevators, automobiles, or carts, within the magnetic field.
  - Consider adequate access for the delivery of dewars containing liquid helium and nitrogen.
  - Consider public access that might pass through the 5-gauss zone.
  - Consider escape routes in case of emergency, including a magnet quench.
  - Consider the location of sensitive electronic equipment that might be affected by the magnetic field. See [Section 2.7, “Magnetic Environment,”](#) on page 30 and [Chapter 5, “Stray Magnetic Fields,”](#) on page 55.
  - For an exact definition of gauss line boundaries, refer to [Section 5.2, “Stray Field Plots,”](#) on page 57 for more information.
  - Make sure you have enough ventilation in case of a quench. Refer to [Section 2.8, “Ventilation,”](#) on page 32.

## 1.3 Transport Route and System Shipping Dimensions

If possible, move the crates in an upright position, with a forklift or hydraulic pallet mover, directly to the installation site.

**CAUTION:** Move the crates in an upright position. Do not drop or mishandle. The crates are packed with G-force and “tip-and-tell” indicators that record mishandling. Be especially careful about moving the magnet crate. If one or more crates cannot be moved into the installation site because of doorway clearance, leave the affected crates in a clean, safe, dry location. Do not open any crate except with direct instructions from an authorized service representative.

The installation site must be accessible from the delivery location with adequate clearance for system crates and moving equipment (including magnet hoist) throughout the access route. Refer to Table 1, Table 2 and Table 3, for the dimensions and weights needed for calculating vertical, horizontal, and turning clearances, and evaluating the structural strength of passageways. Moving the larger crates of the system requires a forklift or hydraulic pallet mover, which must be considered when calculating accessibility.

For an installation site at a different level from the delivery location, be sure that the lifting equipment (such as a forklift or an elevator) is capable of handling the combined weight and size of the shipping crates and the moving equipment.

If it is not possible to access the installation site unless the system is uncrated, contact a Varian service representative. Do not uncrate the system except upon direct instructions from an authorized service representative. To avoid unnecessary expense, be sure moving personnel and equipment are ready for the shipment on the delivery day.

**Table 1.** Cabinet Dimensions as Shipped, with Crate and Pallet

<i>Cabinet</i>	<i>Height cm (in.)</i>	<i>Width cm (in.)</i>	<i>Depth cm (in.)</i>	<i>Weight kg (lb)</i>
NMR console	116.8 (46)	121.9 (48)	101.6 (40)	~ 335 (~ 744)
Third cabinet on 700, or higher systems	148.6 (58.5)	67.5 (26.5)	102 (40)	~ 143 (~ 315)
High-power solids	168 (66)	81 (32)	102 (40)	< 285 (< 630)
Microimaging	168 (66)	81 (32)	102 (40)	~ 240 (~ 530)

**Table 2.** System Accessories Dimensions as Shipped with Crates and Pallets as Appropriate

<i>Accessory</i>	<i>Height cm (in.)</i>	<i>Width cm (in.)</i>	<i>Depth cm (in.)</i>	<i>Weight kg (lb)</i>
RF Front End	32.4(12.75)	95.3(37.5)	88.9(35)	
High Field Preamp Station	33(13)	20.3(8)	69.2(27.25)	
Pneumatics Router	33(13)	20.3(8)	69.2(27.25)	34.6(77)
SMS Autosampler table	104 (41)	104 (41)	135 (53)	159 (350)
SMS Autosampler robot	130 (51)	104 (41)	142 (56)	for both
Granite vibration isolator	10.1(4)	91.4(36)	91.4(36)	308 (680)
NMR work table	31 (12)	188 (74)	115 (45)	89 (196)
Solids Accessory cabinet	94 (37)	72 (28)	97 (38)	90 (198)

**Table 3.** Magnet Dimensions as Shipped with Crate and Pallet

<i>Magnet/Bore*</i> <i>(MHz/mm)</i>	<i>Height</i> <i>cm (in.)</i>	<i>Width</i> <i>cm (in.)</i>	<i>Width**</i> <i>cm (in.)</i>	<i>Depth</i> <i>cm (in.)</i>	<i>Weight</i> <i>kg (lb)</i>
200/54	135 (53)	79 (31)		89 (35)	132 (290)
200/54 LH235	186 (73)	94 (37)	79 (31)	128 (50.5)	468 (1030)
200/54 LH365	186 (73)	94 (37)	79 (31)	128 (50.5)	201 (79)
200/89	186 (73)	94 (37)	79 (31)	128 (50.5)	456 (1003)
300/54	135 (53)	79 (31)		89 (35)	142 (313)
300/54 LH235	186 (73)	94 (37)	79 (31)	128 (50.5)	468 (1030)
300/54 LH365	186 (73)	94 (37)	79 (31)	128 (50.5)	468 (1030)
300/89	186 (73)	94 (37)	79 (31)	128 (50.5)	464 (1021)
400/54	186 (73)	94 (37)	79 (31)	128 (50.5)	538 (1186)
400/54AS	186 (73)	94 (37)	79 (31)	128 (50.5)	538 (1186)
400/54 LH365	186 (73)	94 (37)	79 (31)	128 (50.5)	468 (1030)
400/89	186 (73)	94 (37)	79 (31)	128 (50.5)	571 (1259)
400/89 AS	186 (73)	94 (37)	79 (31)	128 (50.5)	571 (1259)
500/51	203 (80)	94 (37)	79 (31)	128 (50.5)	570 (1257)
500/51 AS	189 (74.5)	94 (37)	79 (31)	128 (50.5)	571 (1259)
500/89 AS	203 (80)	122 (48)	99 (39)	152 (60)	1049 (2308)
600/51AS	203 (80)	122 (48)	99 (39)	152 (60)	1080 (2381)
600/89	203 (80)	122 (48)	99 (39)	152 (60)	1080 (2381)
700/54 AS	320 (126)	210 (84)		210 (84)	35 00 (7716)
750/51	272 (108)	210 (84)		210 (84)	3000 (6614)
800/63	320 (126)	210 (84)		210 (84)	35 00 (7716)
900/54	394.4 (155.3)	225.2 (89)		207.4 (82)	9500 (20944)

\* Long-hold magnets are designated by “LH” and a number that represents hold time in days. Actively shielded magnets are designated by “AS”

\*\* Width with sides and rails removed.

## 1.4 System Shipment

The method of shipping and the current conditions at the destination determine the extent of the receiving preparations. The Varian Order Acknowledgment form indicates the shipping method for the order. The following service is usually provided:

- *Air Freight.* System is delivered to unloading dock or other easily accessible outside unloading point. Factory to destination transit time is about two days (not including time to clear customs).
- *Motor or Moving Van.* System is delivered to an easily accessible interior location or any interior location to which freight can be easily transported by movable dolly. Excluded is transport in elevators that cannot support the weight of the shipment or up stairways. Factory to destination within the United States is about eight days.

## Selecting a Local Shipping Company

Confirm that the local shipping company uses a vehicle that will allow the magnet to be transported in an *upright* position for all transport methods that will be used. See [Table 3](#), [Table 1](#), and [Table 2](#) for dimensions and weights of major system components.

Contact the shipping company locally about the service usually rendered. If moving equipment will be required at the site, obtain help from the plant facilities department or an outside moving service. Sea freight or motor freight without air cushion suspension is not recommended for long distance delivery of systems.

## Postdelivery Inspection

When the system is delivered, follow the instructions below to inspect for shipping damage before moving the crates. *Do not open any crate.*

**CAUTION: Do not open any crate except with direct instructions from an authorized Varian service representative. In particular, the crate containing the magnet has components that could be irreparably damaged if opened incorrectly.**

1. Upon delivery, check for shipping damage but do not open any shipping crates except with direct instructions from an authorized service representative. Examine crates for shipping damage and document any apparent damage as follows:
  - a. Note the nature of the damage on the carrier's waybill.
  - b. Request an inspection and written damage report by a carrier representative.
  - c. Contact the insurance company.
  - d. Forward a copy of the damage report to the local Varian representative.

In case of damage, the FOB block on the Varian Order Acknowledgment form determines owner responsibility:

- **FOB PALO ALTO.** Transfer of ownership occurs when the shipment leaves the factory. The customer is responsible for claims for shipping damage. Upon request, Varian will provide assistance in filing claims.
- **FOB DESTINATION.** Transfer of ownership occurs at customer's point of receipt. Varian is responsible for claims for shipping damage.

Damage discovered fifteen or more days after delivery generally cannot be recovered. Such damage will be at the expense of the customer.

2. As soon as possible, move the shipment to a clean, dry location (preferably the installation site). Move the crates in an upright position. Do not drop or mishandle. The crates are packed with G-force and "tip-and-tell" indicators that record mishandling. If one or more crates cannot be moved into the installation site because of doorway clearance, leave the affected crate in a clean, safe, dry location. Again, do not open any crate except with direct instructions from an authorized service representative. *In particular, the crate containing the magnet has components that could be irreparably damaged if opened incorrectly.*
3. Contact Varian to schedule the visit of an installation engineer after the shipment is moved to the installation site, the utilities are installed, and non-Varian installation parts and supplies (listed in the "Installation Supplies and Equipment" section) are received. For installations in the United States, telephone the Installation Department at (650) 424-4587.



## Chapter 2. Installation Site Requirements

Sections in this chapter:

- 2.1 “Accessibility of Site” page 23
- 2.2 “Site Size” this page
- 2.3 “Ceiling Height Requirements” page 25
- 2.4 “Structural Strength of Floor” page 26
- 2.5 “Floor Vibration Requirements” page 29
- 2.6 “Magnet Support Requirement” page 29
- 2.7 “Magnetic Environment” page 30
- 2.8 “Ventilation” page 32
- 2.9 “Ambient Temperature and Humidity” page 32
- 2.10 “Radio-Frequency Environment” page 33
- 2.11 “Site Altitude and Manostat Pressure Setting” page 36

The NMR spectrometer has certain site requirements, which are described in this chapter. Factors to consider when selecting the installation site include:

- Site size and ceiling height
- Accessibility to the delivery location
- Floor rigidity and structural strength
- Magnetic and radio frequency environment
- Air ventilation, ambient temperature, and humidity

### 2.1 Accessibility of Site

The site must provide adequate access for the routine delivery of supply dewars containing liquid helium and nitrogen. The site must also be accessible for system delivery, as described in [Section 1.3, “Transport Route and System Shipping Dimensions,” on page 19](#)

### 2.2 Site Size

The site must be large enough to allow free access to all sides of the cabinet, magnet, and accessories for operation, maintenance, and cryogenic service. [Table 4](#), [Table 5](#), and [Table 6](#) list the dimensions of the system components, and [Chapter 6, “System Cable Lengths and Room Layouts,” on page 73](#), contains floor plans for the NMR laboratory area or room. The plans are suggestions and not specifications.

All cabinets have casters for easy movement, allowing the system to be placed in a location as small as that illustrated in the section “Minimum Space for 200/54 or 300/54 System

**Table 4.** Cabinets Dimensions and Weights

<i>System</i>	<i>Height cm (in.)</i>	<i>Width cm (in.)</i>	<i>Depth cm (in.)</i>	<i>Weight kg (lb)</i>
NMR console	102.9 (40.5)	110.5 (43.5)	77.5 (30.5)	~ 335 (~ 744)
Third cabinet on 750 or higher systems	124.5 (49)	55.4 (22)	78 (30.7)	~ 136 (~ 300)
High-power solids	142.3 (56)	55.3 (21.8)	78 (30.7)	< 272 (< 600)
Microimaging	142.3 (56)	55.3 (21.8)	78 (30.7)	~ 227 (~ 500)

**Table 5.** Magnet Dimensions with Stand or Legs Attached

<i>Magnet/Bore (MHz/mm)</i>	<i>Height cm (in.)</i>	<i>Cryostat Dia. cm (in.)(excluding anti-vibration legs)</i>	<i>Magnet Weight kg (lb)</i>	<i>Weight with Antivibration kg (lb)</i>
200/54	183 (72)	56 (22)	136 (300)	544 (1200)
200/54 LH 235	230 (90.5)	79 (31)	315 (693)	556 (1225)
200/54 LH 365	230 (90.5)	79 (31)	315 (693)	556 (1225)
200/89	230 (90.5)	79 (31)	391 (860)	456 (1005)
300/54	183 (72)	56 (22)	152 (335)	560 (1235)
300/54 LH 235	230 (90.5)	79 (31)	325 (715)	556 (1225)
300/54 LH 365	230 (90.5)	79 (31)	374 (823)	556 (1225)
300/89	230 (90.5)	79 (31)	399 (878)	506 (1115)
400/54	230 (90.5)	79 (31)	380 (836)	556 (1225)
400/54 LH 365	230 (90.5)	79 (31)	440 (968)	556 (1225)
400/54 AS	230 (90.5)	79 (31)	440 (968)	556 (1225)
400/89 AS	230 (90.5)	79 (31)	410 (902)	660 (1456)
500/51	243 (96)	79 (31)	533 (1173)	671 (1480)
500/51 AS	243 (96)	79 (31)	533 (1173)	671 (1480)
500/89	258 (101.6)	79 (31)	—	777 (1713)
500/89 AS	256 (100.8)	98 (38.6)	—	1250 (2750)
600/51	258 (101.6)	79 (31)	—	672 (1482)
600/51 AS	256 (100.8)	98 (38.6)	—	1081 (2378)
600/89	256 (100.8)	98 (38.6)	—	1081 (2378)
700/54 AS	350 (138)	124 (48.8)	—	3200 (7040)
750/51	331.3 (130.4)	116.8 (46.0)	—	3000 (6614)
800/63 (4.2K)	349.7 (137.6)	118.3 (46.6)	—	4000 (8819)
800/63 (2.2K)	349.7 (137.6)	118.3 (46.6)	—	3000 (6614)
900/54 (2.2K)	490.9 (193.3)	165.1 (65)	—	9900 (19798)

## Notes:

1. Dimensions and weights are typical and can vary  $\pm 5$  cm ( $\pm 2$  in.) or  $\pm 4.5$  kg ( $\pm 10$  lb) from crate to crate.
2. Long-hold magnets are designated by “LH” and a number that represents hold time in days.
3. AS represents actively-shielded magnets
4. Magnets with “—” in the weight column ship standard with the antivibration legs.
5. See [Figure 1](#), [Figure 2](#), and [Figure 3](#) for the various magnet footprints.

**Table 6.** System Accessories Dimensions and Weights

<i>Configuration</i>	<i>Height cm (in.)</i>	<i>Width cm (in.)</i>	<i>Depth cm (in.)</i>	<i>Weight kg (lb)</i>
High Field Preamp Station	95.3(37.5)	32.4(12.75)	88.9(35)	
RF Front End	76.2(30)	20.3(8)	68(26.75)	
Pneumatics Router	53.3(21)	24.1(9.5)	71.1(28)	34.6(77)
SMS Autosampler	71 (28)	34.3 (13.5)	34.3 (13.5)	17 (38)
NMR work table	71 (28)	178 (70)	152 (60)	48 (107)
Solids Accessory cabinet	74 (29)	55 (22)	78 (31)	68 (150)

Without Options,” in “[Minimum Space for a 300/54 System Without Options](#)” on page 75, as long as sufficient space exists for the cabinets to be moved to provide for access to all sides. For comfort and convenience, however, and to provide space for an autosampler or other options, the larger layouts shown in [Chapter 6, “System Cable Lengths and Room Layouts,”](#) on page 73 are highly recommended. The minimum dimensions do *not* include compensation for external magnetic and rf interference that may be present. Each individual site must be analyzed to ensure optimum system performance.

All cabinets have casters for easy movement, allowing the system to be placed in a location as small as that illustrated in [Chapter 6.2, “NMR Room Layouts,”](#) on page 75, as long as sufficient space exists for the cabinets to be moved to provide for access to all sides. The minimum dimensions do *not* include compensation for external magnetic and rf interference that may be present. When setting up a spectrometer, you should try to keep the 5 gauss line inside the lab. The console, power bay, and workstation must be outside the 5 gauss line, see section [2.7 “Magnetic Environment”](#) page 30. If this criteria can not be met please consult with your local installation engineer. Each individual site must be analyzed to ensure optimum system performance.

## 2.3 Ceiling Height Requirements

The ceiling must provide sufficient headroom to insert the liquid-helium transfer tube into the magnet dewar and the storage dewar. The height of the ceiling (or that part of the ceiling located directly above the magnet) without obstructions, such as lighting and heating ducts, *must* be equal to or greater than the minimum heights listed in [Table 7](#). Most helium-level probes are furnished with a flexible section as standard, thus allowing all magnets to be installed within minimum ceiling heights listed in [Table 7](#).

These ceiling minimums allow enough headroom to insert the standard helium flutter tube and refill transfer tubes into the magnet dewar. They also allow use of the standard power stick for running up the magnet field. However, if one of the larger capacity liquid-helium storage dewars is used with the magnet, additional ceiling clearance may be necessary. In general, the ceiling height must be at least twice the height of liquid-helium storage dewar above the floor. Magnets can be provided with optional hinged top-loading components that reduces the minimum ceiling height requirements. Contact Oxford for details.

Most antivibration (i.e., vibration isolation) systems do not increase the ceiling height requirements, with the exception of the 200/54 and 300/54 standard aluminum magnets when placed on an antivibration table system. For these magnets, add 20 cm (8 in.) to the minimum ceiling height requirements.

## 2.4 Structural Strength of Floor

Contact a plant engineer, structural engineer, or registered civil engineer to confirm that the magnet (and antivibration system as applicable) does not exceed the structural floor loading rating. The site floor also must have sufficient structural strength to support the combined weight of the entire spectrometer system and all moving equipment during installation. [Table 4](#), [Table 5](#), and [Table 6](#).

**Table 7. Ceiling Minimum Height**

<i>Magnet/Bore (MHz/mm)</i>	<i>Ceiling Minimum cm (in.)*</i>	<i>Minimum With Flexible Components cm (in.)**</i>
200/54	237 (93)	Not applicable
200/54 LH235	314 (124)	293 (115)
200/54 LH365	314 (124)	293 (115)
200/89	314 (124)	293 (115)
300/54	237 (93)	Not applicable
300/54 LH235	314 (124)	293 (115)
300/54 LH365	314 (124)	293 (115)
300/89	314 (124)	293 (115)
400/54	314 (124)	293 (115)
400/54 LH365	314 (124)	293 (115)
400/54 AS	314 (124)	293 (115)
400/89 AS	314 (124)	293 (115)
500/51	318 (125)	310 (122)
500/51 AS	318 (125)	310 (122)
500/89	343 (135)	319 (126)
500/89 AS	332 (131)	319 (126)
600/51	343 (135)	Not applicable
600/51 AS	332 (131)	319 (126)
600/89	332 (131)	319 (126)
700/54 AS	388 (153)	Not applicable
750/51	379 (149)	Not applicable
800/63	413 (163)	Not applicable
900/54	500 (197)	Not applicable

\* All dimensions include 10 mm to clear the top of the cryostat.

\*\*Flexible components are optional; height provides for a level probe

## Magnet Weight Distribution, With No Antivibration System

This section describes weight distribution for magnets without antivibration systems. The weights of the magnets, including stands, are given in [Table 5](#).

*200/54 and 300/54 magnets* – The plan view of the magnet stand, illustrated in [Figure 1A](#), shows how the two rectangular legs contact the floor. The magnet stand has four adjustable feet of 11.61 cm<sup>2</sup> (1.8 sq. in.) each (totalling 45.16 cm<sup>2</sup> or 7 sq. in.), so the “point loading” is relatively high. Because of the overall light weight of these magnets, this is usually not a concern except in areas with a soft floor covering.

*200/89, 300/89, 400/54, 400/89, and long-hold magnets* – The stands for these magnets consist of three legs, as shown in the plan view in [Figure 1B](#). Because the legs are hollow, the surface contact with the floor is only 167.74 cm<sup>2</sup> (26 sq. in.) total, which creates relatively high “point loading.” This loading is only a concern if the floor covering is soft.

### Magnet Weight Distribution, With Antivibration System

This section describes weight distribution for magnets installed with antivibration systems. Magnet weights, including stands and antivibration systems, are listed in [Table 5](#).

*Magnets equipped with the antivibration tires* – The bottom of the stands consist of a large annular base, as shown in [Figure 3D](#).

*200/54 and 300/54 magnets* – The antivibration system consists of a square table supported by three legs. See [Figure 2](#) for leg placements and sizes.

*200/89, 300/89, 400/54, 400/89, 400/89 AS, 500/89, 500/89 AS, 600/89, 700/54 AS, 750/51, and 800/63 magnets* – The antivibration system for these magnets consists of dampening equipment integrated into the magnet legs. All of these magnets are supported by three legs, as illustrated in [Figure 3A](#), [Figure 3B](#), and [Figure 3C](#).

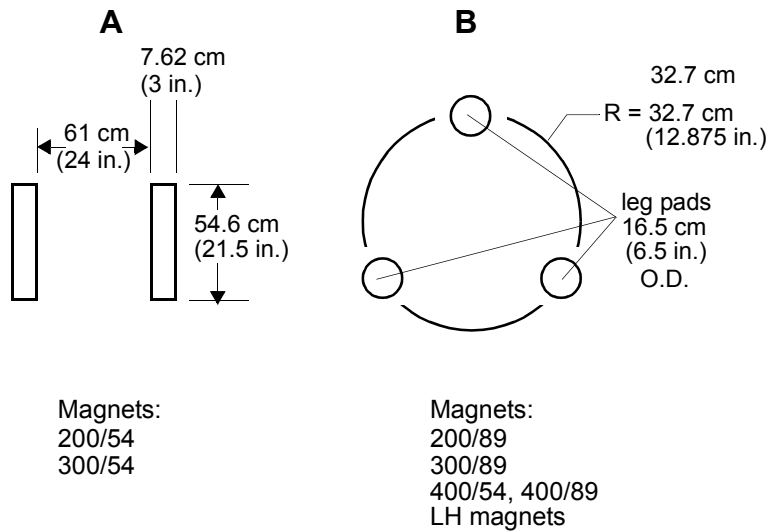

**Figure 1.** Plan Views of Floor Contact Points of Magnet Stands

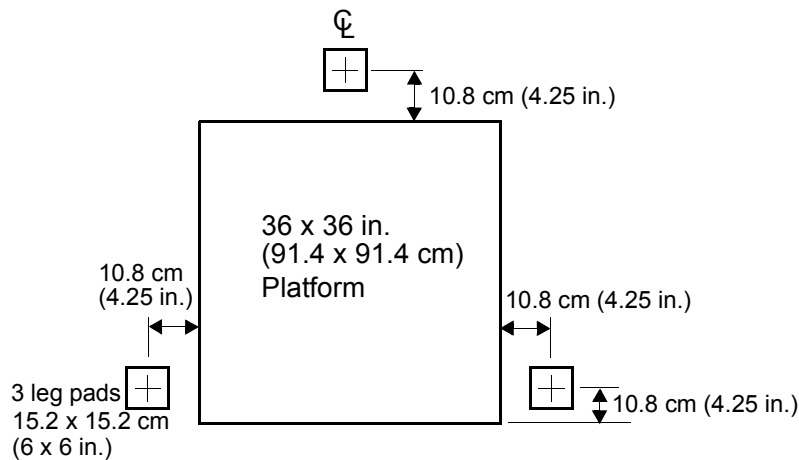

**Figure 2.** Platform Antivibration System Leg Placements and Sizes

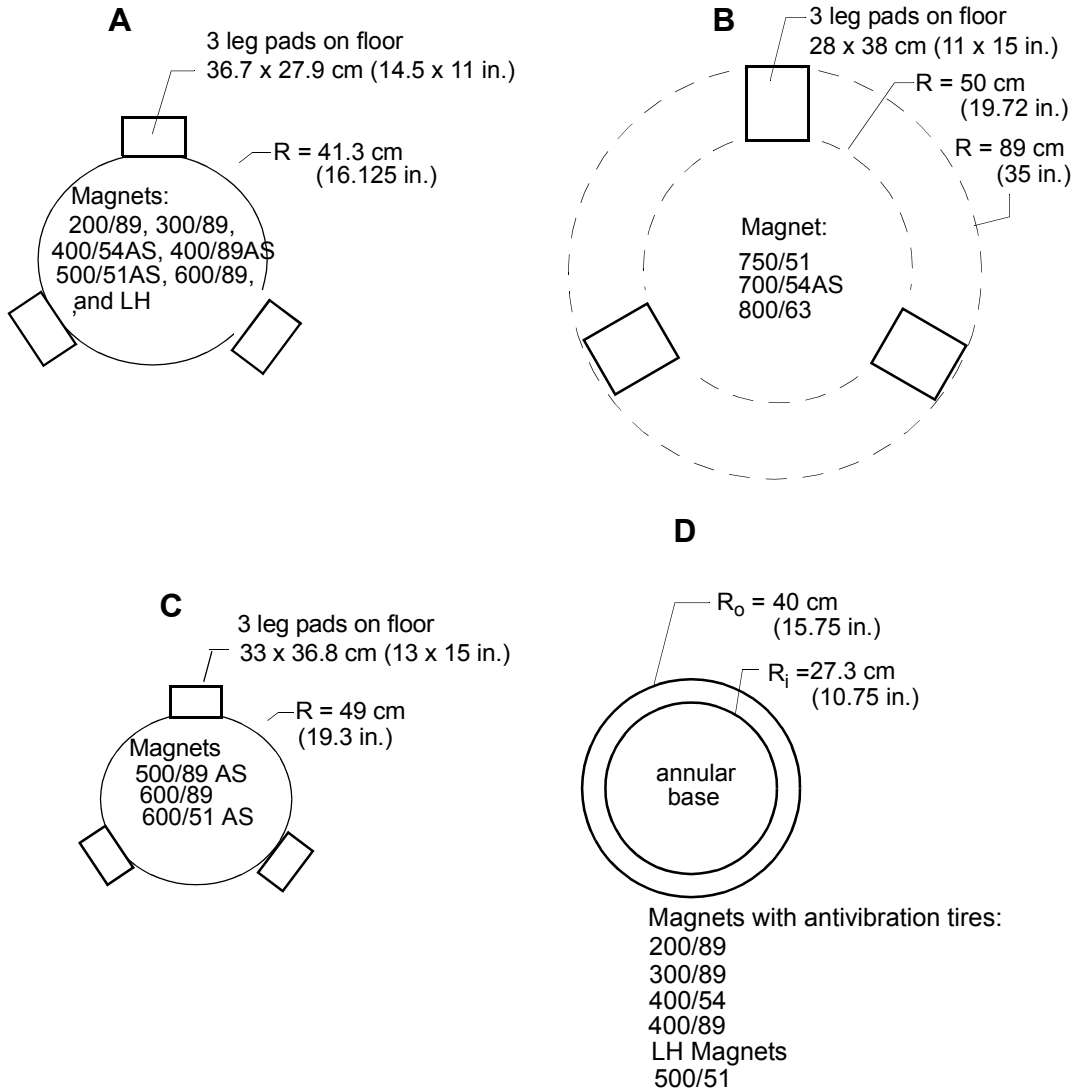

**Figure 3.** Magnet Leg Antivibration Systems Leg Placement and Sizes

900/54 magnet – The antivibration system is incorporated in four legs. Each leg footprint is  $0.454\text{ m} \times 0.454\text{ m} = 0.206\text{ m}^2$ . The magnet weight is 9,900 kg (19,798 lbs).

$$0.206\text{ m}^2 = 2.217\text{ ft}^2$$

$$4\text{ legs} = 8.868\text{ ft}^2\text{ total foot print}$$

$$\text{Therefore the maximum point loading} = 2,233\text{ lb/ft}^2$$

Figure 4 shows the foot print for the 900/54 magnet

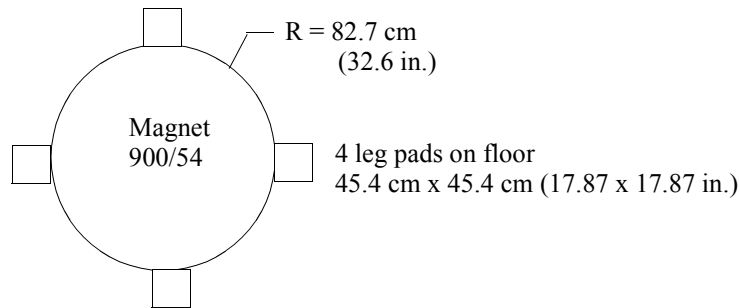

**Figure 4.** Magnet Leg Antivibration 900/54 System Leg Placement and Sizes

## 2.5 Floor Vibration Requirements

The floor must be sufficiently rigid to reduce the vibration from adjacent dynamic loads to a negligible level, defined as no single peak vibration greater than  $20 \mu\text{g}$  acceleration from 5 to 100 Hz.

Ground floor or basement sites are generally preferred for systems because the natural resonant frequencies of most building structures are typically at low frequencies and horizontal in direction. Also cement slabs on grade are preferred to suspended floors because they are stiffer by nature and generally have less low frequency vibrations.

Use of Firestone tire antivibration systems are not recommended at sites with vibrations below 20 Hz or at any site with large vibrations in the horizontal direction. From 20 to 100 Hz there should be no single peak vibration greater than  $200 \mu\text{g}$ .

The maximum allowable vibrations for the anti-vibration pistons (TMC legs) are:

Greater than 15 Hz	no single peak greater than $200 \mu\text{g}$
10 to 15 Hz	no single peak greater than $100 \mu\text{g}$
5 to 10 Hz	no single peak greater than $50 \mu\text{g}$
Less than 5 Hz	no single peak greater than $5 \mu\text{g}$

Measurements are made with an analyzer (Ono Sokki Model CF 200 field FFT analyzer, or equivalent) using 16 rms time averages and with a seismic accelerometer that has  $10 \text{ V/g}$  sensitivity (Wilcoxon Model 731 or equivalent).

## 2.6 Magnet Support Requirement

The magnet has a high center of gravity and could tip over during an earthquake or after being struck by a large object. Therefore, the magnet must be either supported either by ropes attached to the ceiling or by bolting the magnet legs to the floor. Magnet dimensions and weights are listed in [Table 5](#). A structural engineer should be contacted to determine the best restraint method that meets local seismic requirement variations. If overhead ropes are used, the ceiling of the building should be evaluated for structural strength. The ropes should have a small amount of slack so that building vibrations are not transmitted to the magnet. These vibrations can cause artifacts to appear in the NMR spectra.

All systems with antivibration legs must be anchored to the floor. The antivibration system used incorporates the dampening mechanism as an integral part of the magnet leg. As a

result the legs are not rigidly attached to the magnet. In order to work properly they must be firmly attached to the floor. This floor attachment also prevents the tipping of the leg in the case of an earthquake or being struck by a large object. Depending on the seismic requirement, the size of the magnet and the floor material, floor anchoring alone may not be adequate. A structural engineer should be contacted for recommendations. Anchoring to the floor is a standard procedure for many other types of equipment.

Varian expects that the customer's plant or maintenance personnel can usually accomplish anchoring the leg. Varian supplies four 1/2-inch diameter anchor bolts for each leg. A minimum depth of 2.5 in is required for each bolt.

## 2.7 Magnetic Environment

The site must have minimal environmental magnetic fields. Common sources of magnetic interference are fluctuating loads on adjacent power lines, radio or television transmissions, heavy-duty transformers, elevator motors, and similar electromagnetic devices. Allow a separation of at least 4.6 m (15 ft) between the magnet and other high-field electromagnets, elevators, or forklift trucks.

Similar separation distances must also be maintained between the magnet and anything that can cause a detrimental effect on the field homogeneity or the structural integrity of the magnet. Conditions that could interfere with the magnet include (but by no means limited to) a wall with metal sheathing or steel studding, a concrete support column with steel reinforcing bars, and a storage area containing steel dewars for cryogenic storage. Each site must be carefully analyzed to ensure optimum performance of the system. See [Table 8](#) for examples of objects that affect or are affected by the magnetic field.

The CRT in color monitors needs to be degaussed in magnetic fields above 1 to 2 gauss. Above 5 gauss, color monitors may need additional shielding to prevent display distortion. Sun workstations and peripherals are also affected by the magnetic field; refer to [Section 3.11, "Host Workstation Preparation,"](#) on page 45 for a discussion of magnetic field considerations.

Because the magnetic field exists both horizontally and vertically, the effect of the field on persons, electronic equipment, computers, and other objects located above and below the magnet must be considered. Pacemaker hazard and other signs warning that a magnetic field is present may be needed in the space on the next floor above the magnet and on the floor below the magnet. [Figure 5](#) shows the typical elliptical profile of the vertical (axial) stray magnetic fields for the 400-, 500-, 600-, 700-, 750-, and 800-MHz magnet systems (drawing is not to scale). Refer to [Section 5.2, "Stray Field Plots,"](#) on page 57 for stray magnetic field values.

**Table 8.** Interaction Between a Magnetic Field and Common Objects

<i>Magnetic Field</i>	<i>Objects That Affect the Magnetic Field</i>
15 gauss line or closer	All ferromagnetic construction materials except small amounts of steel reinforcing bar, normally not exceeding 11 kg/m <sup>2</sup> (2.5 lb/ft <sup>2</sup> ).
5 to 15 gauss	Presence or movement of ferromagnetic objects over 45 kg (100 lb), such as pushcarts, hand trucks, gas cylinders.
2 to 5 gauss	Presence or movement of ferromagnetic objects over 450 kg (1000 lb), such as small delivery trucks, automobiles, pallet movers, forklifts, and elevators.
1 to 2 gauss	Presence or movement of ferromagnetic objects over 34,000 kg (75,000 lb), such as trains, large trucks.

<i>Magnetic Field</i>	<i>Objects Affected by the Magnetic Field</i>
15 gauss line or closer	Cardiac pacemakers, ferromagnetic implants, and unrestrained ferromagnetic objects, such as tools, keys, electronic equipment, analog watches, magnetic data storage media, and credit cards.
5 to 15 gauss	Cardiac pacemakers and electronic equipment, such as shielded CRTs, computers, shielded image intensifiers, and shielded photomultiplier tubes.
2 to 5 gauss	Very sensitive electronic equipment, such as unshielded image intensifiers and photomultiplier tubes.
1 to 2 gauss	Extremely sensitive electronic equipment, such as linear accelerators, electron microscopes, and CRTs.

**Figure 5.** Typical Vertical Stray Fields for High-Field Magnets

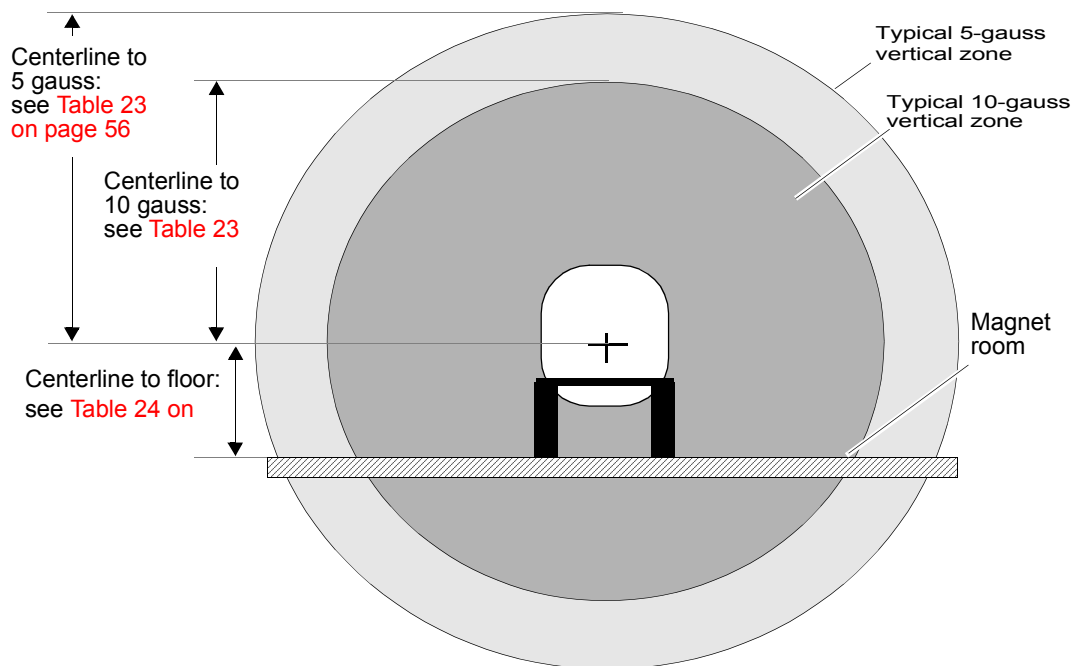
## 2.8 Ventilation

Air ventilation must be adequate to displace the liquid helium gas during a quench, especially when using any type of volatile liquid for variable temperature experiments. Consult with a safety engineer on this subject. Gaseous helium or nitrogen exhausted from the magnet will displace oxygen and cause asphyxiation if not properly ventilated. During a magnet quench, the evaporated helium is exhausted from the manifold by the pressure relief valves. The amount of gas depends on the amount of liquid helium held by the magnet at the time of the quench. **Table 9** lists the approximate total amount of liquid helium for each magnet system. But it is unlikely that a magnet quench will boil off the total amount listed in the table. Also, remember that vented helium gas fills the room from the ceiling down, so place fans and ducts accordingly.

The expansion ratio of liquid helium at room temperature is about 740:1, which means that one liter of liquid helium expands to about 740 liters of helium gas.

- For fans rated in LPM (liters per minute), multiply the LHe maximum volume listed in **Table 9** by 740 to get an idea of helium gas the fan should be capable of displacing.
- For fans rated in CFM (cubic feet per minute), multiply the LHe maximum volume listed in **Table 9** by 26.13 (includes expansion ratio) to get an idea of the total amount of helium gas that the fan should be capable of displacing (e.g., a magnet that holds 30 liters of LHe will require a fan that can displace about 784 ft<sup>3</sup> of helium gas).

**Note:** On magnets where a quench vent and duct work is used to direct the helium gas out of the area during a quench, the orientation of the quench vent and its duct work must be placed so that it doesn't interfere with a four inch (10.2 cm) radius cylinder extending up from the magnet's room temperature bore.

**Table 9.** Liquid Helium Displacement for Room Ventilation Considerations

<i>Magnet/Bore (MHz/mm)</i>	<i>LHe Maximum Volume (liters)</i>
200/54	30
200/54 LH235	87
200/54 LH365	136
200/89	76
300/54	30
300/54 LH235	87
300/54 LH365	136
300/89	76
400/54	74
400/54 LH365	123
400/54 AS	123
400/89 AS	69
500/51	69
500/51 AS	130
500/89	130
600/51	130
600/51 AS	198
600/89	115
700/54 AS	370
750/51	440
800/63	450
900/54	1350

## 2.9 Ambient Temperature and Humidity

**Table 10** lists the required ambient temperature ranges, temperature stability, and humidity levels for the site. For optimal performance, the ambient temperature around the magnet should not vary. Magnet homogeneity is optimized if the ambient temperature stability is maintained for the duration of an experiment and between shimming. Sunlight should never shine directly on the magnet or the area surrounding the magnet.

If necessary, install an air conditioning system to maintain the required conditions. Keep the air conditioning system operating continuously to stabilize the temperature and humidity surrounding the spectrometer system. The air flow from the room heating and cooling system must not blow on the magnet. Do not allow moisture to collect on, in, or around the system. At high altitudes (above 5000 ft), the cooling efficiency for the electronics is lower. This can be compensated for by lowering the room temperature by one or two degrees from the room temperature specification.

**Table 10.** Ambient Temperature and Relative Humidity

<i>Mode</i>	<i>Temperature</i>		<i>Relative Humidity Noncondensing</i>
	<i>° C</i>	<i>° F</i>	
Operational range	17 to 24	60 to 75	20% to 80%
Optimum	20	68	40% to 60%
Temperature stability	± 1.0	± 1.8	
Nonoperational range	-20 to 60	-4 to 140	8% to 80%

## 2.10 Radio-Frequency Environment

The site should be checked for radio-frequency interference (rfi) at or near the operating frequencies of the spectrometer, listed in Table 11, and most common nuclei, listed in Table 12). The level of any interference should be attenuated to an electrical field strength of less than 150  $\mu\text{V}/\text{m}$  at the site of the magnet. Interference often occurs when two spectrometers are located in the same room, referenced to the same power system, or operating at the same frequency.

**Table 11.** Operating Frequencies for NMR Spectrometers

<i>Proton Frequency (MHz)</i>	<i>Frequency Range (MHz)</i>
200	12 to 215
300	12 to 325
400	12 to 430
500	12 to 538
600	12 to 645
700	12 to 751
750	12 to 807
800	12 to 859
900	12 to 965

### Radio-Frequency Interference

Most radio-frequency interference (rfi) comes from transmissions for radio, television, paging systems, and cellular telephones. Some emission comes from electrical and electronic equipment in the immediate area. The horizontal NMR imaging system has a shielded magnet bore and is not sensitive to average rfi levels. If the room level exceeds 10,000  $\mu\text{V}/\text{m}$ , additional shielding may be required.

**Table 12.** Operating Frequencies for Common Nuclei

<i>Nuclei</i>	<i>200</i>	<i>300</i>	<i>400</i>	<i>500</i>	<i>600</i>	<i>700</i>	<i>750</i>	<i>800</i>	<i>900</i>
<sup>1</sup> H	200.06	299.95	399.94	499.95	599.95	700.00	749.95	800.45	900.08
<sup>19</sup> F	188.22	282.20	376.29	470.39	564.45	658.66	705.66	753.40	846.92
<sup>31</sup> P	80.98	121.42	161.90	202.39	242.85	283.37	291.46	324.14	364.36
<sup>13</sup> C	50.31	75.43	100.58	125.73	150.87	176.02	188.58	201.38	226.33
<sup>29</sup> Si	39.75	59.59	79.46	99.33	119.20	139.07	148.99	159.11	178.82
<sup>2</sup> H	30.71	46.04	61.40	76.75	92.09	107.45	115.12	122.22	138.17
<sup>15</sup> N	20.28	30.41	40.54	50.68	60.80	70.957	76.02	81.16	91.24
<sup>39</sup> K	—	14.00	18.66	23.33	28.00	32.67	34.99	37.36	42.00

### Radio-Frequency Emissions from Varian NMR Equipment

RF emissions from Varian NMR equipment has been measured and compared with IEEE/ANSI C95.1–1991, “Standard for Safety Levels with Respect to Human Exposure to RF Radiation.” The rf tests included general measurements of systems with particular interest directed toward amplifiers, transmitter boards, and probes. With maximum observe transmitter and decoupler transmitter power applied (parameters  $\tau_{pwr}$  and  $d_{pwr}$  set to 63), measurements were taken both 12 inches away and as close as possible to the rf source while the source was installed in the console or magnet

The results of the tests, shown in [Table 14](#) found that rf emissions from Varian NMR equipment either were not detectable or were detectable at levels far below the IEEE/ANSI C95.1–1991 Standard levels, which are shown in [Table 13](#).

**Table 13.** IEEE/ANSI C95.1–1991 Standard for RF Radiation Levels

<i>Frequency (MHz)</i>	<i>E-Field (mW/cm<sup>2</sup>)</i>	<i>H-Field (mW/cm<sup>2</sup>)</i>
50	1.0	4.0
75	1.0	1.8
125, 150	1.0	1.0
200, 300	1.0	1.0
500	1.7	1.7
600	2.0	2.0
700, 750, 800, 900	2.5	2.5

**Table 14.** Results of RF Emissions Tests on Varian NMR Equipment

<i>Spectrometer System and NMR Experiment</i>	<i>Frequency (MHz)</i>	<i>RF at Probe (mW/cm<sup>2</sup>)</i>	<i>RF at Amplifier (mW/cm<sup>2</sup>)</i>	<i>IEEE/ANSI C95.1-1991</i>
<b>600-MHz</b>				
Carbon observe	150	0 E-field	0 E-field	1.0 E-field
$t_{pwr}=58$ pulse		0 H-field	0 H-field	1.0 H-field
Carbon observe	150	0 E-field	0 E-field	1.0 E-field
$t_{pwr}=63$ pulse, 50-ohm load		0 H-field	0 H-field	1.0 H-field
Proton observe	600	0 E-field	0 E-field	2.0 E-field
$t_{pwr}=63$ pulse		0 H-field	0 H-field	2.0 H-field
Proton observe	600	0 E-field	0.05 E-field	2.0 E-field
$t_{pwr}=63$ pulse, 50-ohm load		0 H-field	0.05 H-field	2.0 H-field
<b>500-MHz</b>				
Carbon observe	125	0 E-field	0 E-field	1.0 E-field
$t_{pwr}=63$ , $d_{pwr}=63$ pulse terminated		0.05 H-field	0.01 H-field	1.0 H-field
Carbon observe	125	0.01 E-field	0.05 E-field	1.0 E-field
$t_{pwr}=63$ pulse, 50-ohm load		0.2 H-field	0.02 H-field	1.0 H-field
Proton observe	500	0.25 E-field	0.05 E-field	1.7 E-field
$t_{pwr}=63$ pulse		0.25 H-field	0.05 H-field	1.7 H-field
Proton observe	500	0.25 E-field	0.05 E-field	1.7 E-field
$t_{pwr}=63$ pulse, 50-ohm load		0.25 H-field	0.05 H-field	1.7 H-field
<b>200-,300-, 400-MHz</b>				
Cross-polarization	75	0.005 E-field	0 E-field	1.0 E-field
300 W, 2 ms pulse		0.05 H-field	0.005 H-field	1.8 H-field
Cross-polarization	300	0.1 E-field	0 E-field	1.0 E-field
100 W, 20 ms pulse		0.1 H-field	0 H-field	1.0 H-field
<b>CMA amplifier</b>				
Cross-polarization	75	0.005 E-field	0 E-field	1.0 E-field
300 W, 2 ms pulse		0.05 H-field	0.005 H-field	1.8 H-field
Cross-polarization	300	0.1 E-field	0 E-field	1.0 E-field
100 W, 20 ms pulse		0.1 H-field	0 H-field	1.0 H-field

## 2.11 Site Altitude and Manostat Pressure Setting

Set the manostat pressure value to 1035 mbar or (of the location is at altitude) refer to **Figure 6** for an appropriate value. Monitor the cryostat pressure until control is established; gas flows from the exit port and pressure is constant at the set value. This can take several hours depending on the actual system boiloff. Refer to the magnet manual for more details.

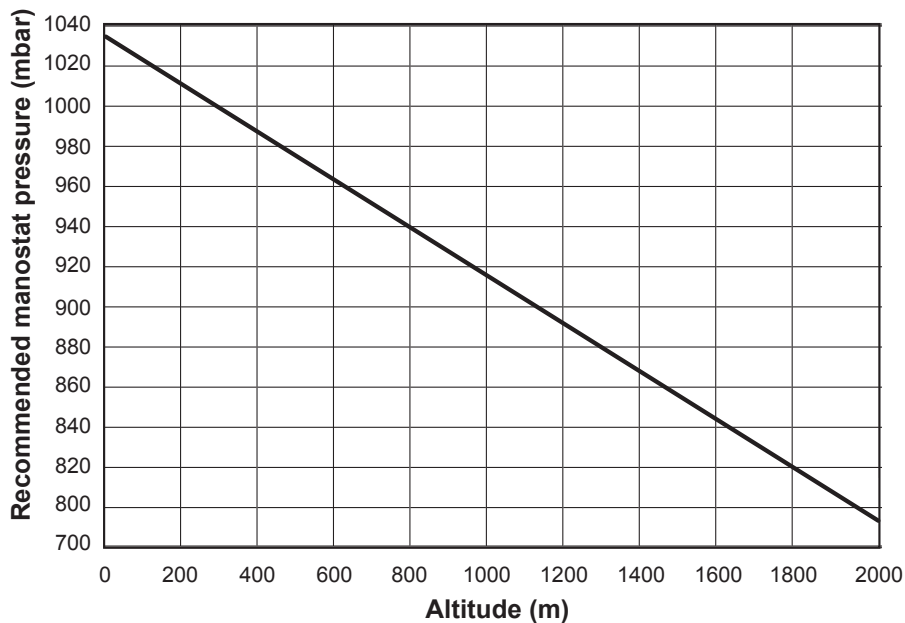

**Figure 6.** Recommended Manostat Set Pressure as a Function of Altitude

## Chapter 3. Site Preparation

Sections in this chapter:

- 3.1 “Line Voltage Variation” this page
- 3.2 “Uninterrupted Power Supply” page 38
- 3.3 “Electrical Outlets” page 38
- 3.4 “Separate Air Sources for System Options” page 40
- 3.5 “Compressed Air Supply” page 41
- 3.6 “Compressed Nitrogen Gas” page 42
- 3.7 “Gas Supplies for Solids Systems” page 42
- 3.8 “AC Power and Air Conditioning” page 43
- 3.9 “Telephone and Internet Access” page 43
- 3.10 “Electrostatic Discharges” page 45
- 3.11 “Host Workstation Preparation” page 45

Verify the configuration with a Varian, Inc. representative before designing the room layout. Site preparation must conform with federal, state, and local codes, which take precedence over recommendations in this guide. Approval by a building inspector may be necessary.

**IMPORTANT:** Before installing the NMR spectrometer, confirm that the mains power for the site is supplied by a dedicated distribution transformer. Do not connect the spectrometer directly to the public low voltage network. Contact a Varian representative if the site does not have a dedicated transformer.

### 3.1 Line Voltage Variation

200-, 300-, 400-, 500-, and 600-MHz spectrometers require one line tap at 200, 208, 220, 230, or 240 Vac, single phase, depending on the voltage selector setting. 700-, 750-, 800-, and 900-MHz systems require two 220 Vac, single-phase lines. Current ratings for these taps are listed in [Table 15](#).

Measure and record the ac line voltage for 48 hours using a suitable power line analyzer, such as the BMI Model 4800 or equivalent. Provide a copy for the Varian installation engineer. Requirements are the following:

- Long-term voltage variations (slow average) do not exceed 7% of nominal line tap voltages.
- Short-term voltage variations (sag or surge), with a duration between several milliseconds and several seconds, do not exceed 10% of nominal line tap voltage.

- Line transients (impulse), with a duration between 1  $\mu$ s and 800  $\mu$ s, do not exceed 50 V peak above or below nominal line tap voltage. These transients must be measured at the power plug with a load connected that draws the same power as the spectrometer.
- AC line frequency does not vary by more than +0.5 to –1.0 Hz.

Installing a line conditioner and regulator is strongly recommended. By providing protection against transients and improving line regulation, total system “up-time” improves and the electronic components within the system last longer. In many locations, a good power conditioning system can pay for itself within a few years. Contact a local power consultant for suitable equipment in your area.

## 3.2 Uninterrupted Power Supply

If your site experiences frequent and short (less than 10 minutes) power outages, you should consider installing an uninterrupted power supply (UPS). UPS systems are limited in how long they can supply power when house power is out. Consider the placement of a UPS when planning your lab. If you want to use a single UPS, it must have output for 220 Vac and 120 Vac and it must be installed such that both the NMR console and the host workstation can use it. Solids systems require more than one transformer.

To determine the power rating for the UPS (in kW), refer to [Table 18 on page 44](#) and add the values (kW) for the accessories with your system.

## 3.3 Electrical Outlets

[Table 15](#) lists the electrical outlet requirements of system components. The sections below details the requirements of each component.

**Table 15.** Electrical Outlets/Circuits Requirements

<i>Component</i>	<i>Required Number of Outlets/ Circuits</i>	<i>Electrical Requirements (single phase at 50-60 Hz)</i>
two-cabinet console	1	200, 208, 220, 230, 240 Vac, 20 A
Pneumatics Router	1	120/220 Vac, 15 A
Host workstation and peripherals	6	120/220 Vac, 15A minimum
LC-NMR accessory	5	120 or 220 Vac, 15 A
SMS autosampler accessory	1	120 or 220 Vac, 15 A
Carousel autosampler accessory	1	120 or 220 Vac, 15 A
VAST autosampler accessory	2	120 or 220 Vac, 15 A
Accessories and test equipment	6	120 Vac, 20 A or 230 Vac, 10 A
Solid-state Power cabinet (Channels 1&2)	1	208/220/240 Vac, 30 A
Solid-state Power cabinet (Channels 3&4)	1	208/220/240 Vac, 30 A
Solid-state Accessory cabinet	1	90–132 Vac, 15 A or 190–240 Vac 15 A
Microimaging module cabinet	1	see text
Third cabinet for 750- or 800-MHz	1	220 Vac, 30 A
VT CP/MAS module	1	110–125 Vac, 15 A (USA) 220–240 Vac, 15 A (Europe)
Diffusion	1	3 $\emptyset$ (L500)

**Two-Cabinet Console** – The standard two-cabinet has a selectable power supply (200, 208, 220, 230, 240 Vac) to match the building ac voltage. The console requires a dedicated single-phase, continuous-duty 200 to 240 Vac ( $\pm 5\%$ ), 50/60 Hz power line with 20-A minimum service (for up to 4 channels). Terminate this line within 3 m (10 ft) of the left side (looking from the rear) of the standard cabinet with a fused, quick-disconnect switch box or circuit breaker. Run a separate, insulated, low-resistance earth ground to the main electrical service entrance ground.

**Pneumatics Router** – One, 110/220 Vac, 15 A, outlet within 3 m (9 ft) of where the Pneumatics Router will be placed.

**Host Workstation and Peripherals** – The host workstation and accessories require a minimum of six 120-Vac, single-phase power outlets. If your location has ac voltages over 132 Vac, you should check with your local Varian service center for power outlet requirements. Locations with ac voltages over 125 Vac might need at least one step-down transformer. The Host workstation and peripherals can operate in the Asian market 190 to 205 V range. To minimize ground loop interference, electrical outlets should all be on the same 20-A service. *Surge protection is strongly recommended.*

**Third Cabinet for 700-MHz and Higher Field Systems** – The third cabinet requires a dedicated single-phase, continuous-duty 220 Vac ( $\pm 7\%$ ), 50/60 Hz power line with 30-A minimum service. Terminate this line within 3 m (10 ft) of the left side (looking from the rear) of the standard cabinet with a fused, quick-disconnect switch box or circuit breaker. Run a separate, insulated, low-resistance earth ground to the main electrical service entrance ground.

**Solid-State Power Cabinets (Channels 1 & 2/Channels 3 & 4)** – Systems with high power amplifiers on channels 1 & 2 (supplied in a third cabinet) require an additional 208/220/240-Vac single-phase, 30 A dedicated line. Systems with high power amplifiers on channels 3 & 4 (supplied in a fourth cabinet) require one more 208/220/240-Vac single-phase, 30 A dedicated line. These lines are required for these power bays only and are in addition to the line for the main two-cabinet console. For solids modules that do not have the higher power amplifiers in these cabinets no additional electrical power is required except when a Solids Accessory cabinet is part of the system, that is discussed in its own paragraph in this section.

**Solid-State Accessories Cabinet** – The Solid-State Accessory cabinet can be powered off of either a 90-132 Vac 15 A circuit or a 190-240 Vac 15 A circuit. The cabinet is supplied with cord with a three prong (NEMA-5-15P) plug except in Europe where it is supplied with a “Schuko” plug (CEE 7/7).

**VT CP/MAS Module** – A dedicated, single-phase, continuous-duty 50/60 Hz power line is required. The line should be 110 to 124 Vac, 15-A in the United States and 220 to 240 Vac, 15-A elsewhere. In addition, the customer must supply a 3-prong polarized plug compatible with the site voltage.

**Microimaging Module Cabinet** – The gradient power cabinet of the microimaging module contains three Highland L500 gradient amplifiers and a power distribution unit (PDU). Because the cabinet requires considerable electrical power, customers must provide a dedicated three-phase (3 $\phi$ ) power line to a wall-mounted circuit breaker and wiring from the circuit breaker to the PDU. All wiring must conform to local electrical codes. For three-phase wiring configuration and requirements, check with your Varian representative. The 5-m (16.5-ft) 5-conductor cable to the PDU is supplied by Varian without connectors.

**Figure 7** shows the internal wiring of the gradient cabinet.

As shown in **Table 16**, Highland L500 amplifiers can be configured to the four input voltages. Varian recommends the 208 Vac model for U.S. installations and the 380 Vac model for most other installations (e.g., Europe). The customer must communicate the

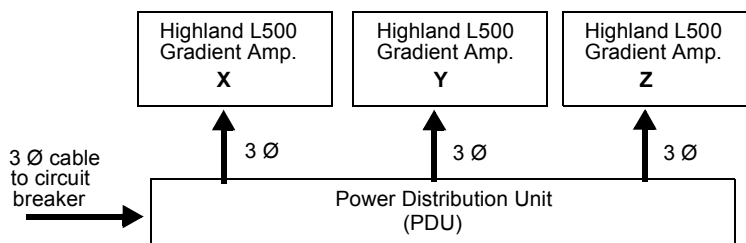

**Figure 7.** Internal Wiring of Gradient Cabinet

choice of power input voltage and mains frequency to Varian well in advance of the spectrometer shipping date so that the correct Highland L500 models are included.

**Table 16.** Models of Highland L500 Gradient Amplifiers

<i>Wall (3Ø)</i>	<i>PDU Breaker</i>	<i>Highland</i>
208 Vac, 30 amp	30 A	208 Vac
240 Vac, 30 amp	30 A	240 Vac
380 Vac, 15 amp	15 A	380 Vac
416 Vac, 15 amp	15 A	416 Vac

**LC-NMR Accessory** – Five, 110 Vac or 220 Vac outlets within 2 m (6 ft) of where the table holding the LC hardware will be located. Several extension cords should be for the installation.

**SMS Autosampler** – A 120 or 220 Vac, single-phase, continuous-duty 50/60 Hz power line, 15 A minimum service, is required within 2.7 m (9 ft) of the magnet.

**Carousel Autosampler** – A 120 or 220 Vac, single-phase, continuous-duty 50/60 Hz power line, 15 A minimum service, is required.

**VAST Autosampler** – Two 120 or 220 Vac, single-phase, continuous-duty 50/60 Hz power lines, 15 A minimum service, are required within 2 m (6 ft) of VAST table.

**Pulsed Field Gradients Accessories** – Single-axis (Z axis) PFG accessories use standard system power and require no special electrical outlets.

**Diffusion Accessory** – requires 3-phase power for the L500 amplifier.

**Other Accessories and Test Equipment** – At least six outlets are needed within 1.8 m (6 ft) of the host workstation, standard cabinet, and magnet. The outlets must have ground connections and provide a minimum of 2.30 kVA at the local single-phase line voltage (120 Vac at 20 A, or 230 Vac at 10 A).

### 3.4 Separate Air Sources for System Options

The vibration isolation table and antivibration legs require a separate air regulator supplied by Varian. The air pressure requirements should be 80 psi. Using the spectrometer or sample changer regulator with the antivibration system causes the magnet to vibrate.

A system equipped with a vibration table or isolators for the magnet also requires a separate air source and regulator. Bottled gas is not recommended for long-term operation.

The CP/MAS and CRAMPS solids options also require a separate regulated air source (or nitrogen gas for variable temperature operation) with 620 kPa (90 psig) pressure at the wall. Dewpoint should be  $-193^{\circ}\text{C}$  (80 K) and oil removal greater than 99.5%. Filtration should be to 0.6 microns. The minimum flowrate at the wall is 80 lpm.

**CAUTION:** Contaminated air can cause extensive damage to the solids probe.

## 3.5 Compressed Air Supply

The house compressed air supply must provide a source of air that is clean, dry, and free of contaminants, with a dew point of  $-40^{\circ}\text{C}$  ( $-40^{\circ}\text{F}$ ) minimum. The dew point must be  $-60^{\circ}\text{C}$  for the FTS coolers (preconditioning units) that are standard on 700-MHz and higher field magnets. The source should include a reservoir and be capable of delivering the air pressures (in kilopascals or pounds-per-square-inch-gauge) and flow rates (in liters-per-minute or standard cubic-feet-per-hour) after filtering as given in [Table 17](#).

**Table 17.** Compressed Air Supply Source

<i>System Configuration</i>	<i>Pressure</i>	<i>Flow Rate</i>
200, 300, or 400 system with liquids only, no options (air source needed for spin, probe cooling, VT, and eject):		
Normal operation	585 kPa (80 psig)	27 LPM (57 SCFH)
During sample eject	585 kPa (80 psig)	45 LPM (95 SCFH)
500, 600, 700, 750, 800, or 900 system with liquids only, no options (air source needed for spin, probe/shim cooling, VT, and eject):		
Normal operation	585 kPa (80 psig)	27 LPM (57 SCFH)
During sample eject	585 kPa (80 psig)	48 LPM (102 SCFH)
System with wideline module:	Same as above	
System with third/fourth rf channel:	Same as above	
System with gHX Nano probe	585 kPa (80 psig)	45 LPM (95 SCFH)
System with Jacobson probes, Solid-State MAS Spinning:	620 kPa (90 psig)	80 LPM (170 SCFH)
System with Doty probe, Solid-State MAS Spinning:	620 kPa (90 psig)	50 LPM (106 SCFH)
System with microimaging module:		
Gradient coil cooling	585 kPa (80 psig)	50 LPM (106 SCFH)
Probe cooling	585 kPa (80 psig)	20 LPM (42 SCFH)
System with antivibration systems:	585 kPa (80 psig)	4 LPM
System with Chemagnetics probes, Solid-State VT and Probe purge:	585 kPa (80 psig)	169 LPM (360 SCFH)
System with Chemagnetics probes, Solid-State MAS Spinning:	620 kPa (90 psig)	141 LPM(300 SCFH)

Install a gate valve on the permanent outlet of the air supply line. The gate valve must be rated at least 860 kPa (125 psi or 9 kg/cm<sup>2</sup>). If the house line pressure is greater than this level, the valve must be rated at a level that exceeds the house pressure. Attach to the valve a minimum 1 cm (0.4 in.) pipe terminated with a 1/4-inch male NPT. Make the pipe long enough so that its termination fitting is within 4.5 m (15 ft) of the planned location of the magnet. A primary air regulator capable of  $\pm 2$  psi is also required upstream from the gate valve.

In areas where humidity is high or where moisture in the air supply is a problem, consider installing a prefilter with an automatic drain to help prevent overload of the filter. In extreme cases, an air dryer assembly may be necessary. These units must be provided by the customer. The source should include a reservoir and be capable of delivering the air pressures (in kilopascals or pounds-per-square-inch-gauge) and flow rates (in liters-per-minute or standard cubic-feet-per-hour) after filtering as given in [Table 17](#).

Designing to the flow rates stated in Table 17 should give optimum compressor life with a high quality of air. A coalescing filter and particulate filter are required for solids accessories and must be supplied by the customer. The particulate filter should be capable of filtering to 0.1 micron.

If a portable compressor is used as the air supply, the unit should have a holding tank capacity of 80 gallons (303 liters) to avoid the compressor cycling off and on. In moist environments, an air dryer is also usually necessary, as well as an automatic drain on the holding tank. Systems with TMC anti vibration legs require 80 psi.

The installation engineer will install on your air termination fitting a Varian-supplied assembly that includes a 0 to 690 kPa (0 to 100 psi) pressure gauge, a reduction valve, a standard 20 micron air filter, a coalescing oil filter (99.9 percent oil removal efficiency), and an air line to the magnet.

### 3.6 Compressed Nitrogen Gas

During operation of the variable temperature accessory, a compressed nitrogen gas supply (from a cylinder or a fixed line) is required that is dry, oil-free, and magnetically clean (e.g., free of rust), with a dew point of  $-193^{\circ}\text{C}$  (80 K). The flow and pressure rates through the regulators are the same as those listed for the compressed air supply.

### 3.7 Gas Supplies for Solids Systems

Varian, Inc. recommends using a three-way or diverting-ball valve to allow switching of gas sources. With this valve installed, each supply line will have a shut-off valve and regulator on the supply side of the switching valve. The first stage regulators can be omitted if the line pressure downstream of the regulator will be less than 90 psi with the regulator in-line. As a general practice, both VT and spinning will run off of nitrogen gas or compressed air; the sources are not normally different for the two outputs. Varian, Inc. does not recommend using a quick-connect fitting to switch sources since they usually introduce a significant flow restriction. Varian, Inc. supplies a Tee fitting with adaptors to go from 1/2-inch NPT female fitting to the connections for the air management box and the MAS speed controller. A 3/8-inch hose barb fitting is included as an alternate input in the Tee in case the 1/2-inch NPT is not available. Refer to [Figure 8](#)

The delivery pipes should be at least 1/2-inch copper piping specified as *air handling lines*.

Install a ball valve on the permanent outlet of the air supply line. The ball valve must be rated at least 860 kPa (125 psi or  $9\text{ kg/cm}^2$ ), with an open diameter matched to the copper piping. If the house line pressure is greater than this level, the valve must be rated at a level that exceeds the house pressure. Attach to the valve a minimum 1 cm (0.5 in.) pipe terminated with a 1/2-inch male NPT. The termination fitting should be within 6 m (20 ft) of the planned location of the accessory cabinet. A first stage air regulator, see [Figure 8](#),

capable of  $\pm 2$  psi is also suggested upstream from the ball valve when 90 psi, or greater, can be reached at the output.

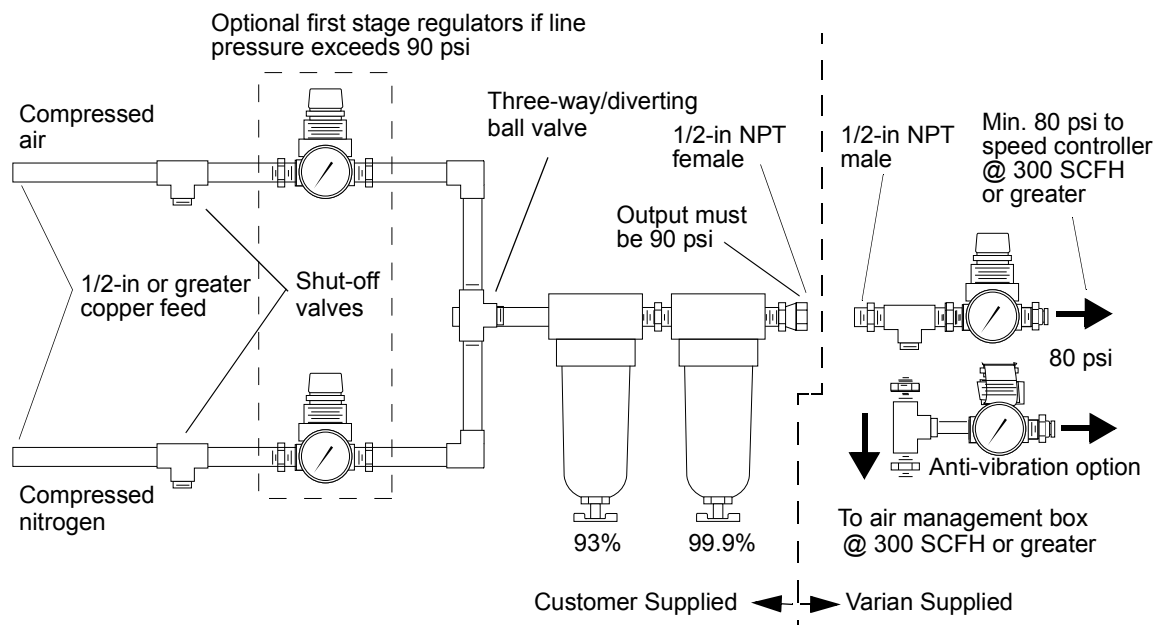

Figure 8. Setup for Switching Gas Supplies

### 3.8 AC Power and Air Conditioning

Use [Table 18](#) to help determine *maximum* surge current, line conditioning, and air conditioning requirements. The surge current can be reduced by setting each rf amplifier to the off position using the rf amplifier switch on the rear panel, and then switching on the spectrometer power and turning on each rf amplifier separately.

A filter on the air conditioning unit intake and special air filtration is required in installations exposed to corrosive gases, salt air, or unusual dirt or dust conditions. The air conditioning system requires a power line separate from the spectrometer system.

### 3.9 Telephone and Internet Access

Varian recommends locating a regular voice telephone line near the host workstation. This telephone would enable the spectrometer operator to discuss the spectrometer system as it operates.

Varian also strongly recommends that Internet access be provided during and after system installation. By providing external access to the spectrometer, technical problems can be quickly analyzed by the engineering and scientific staff at Palo Alto. After the system is installed, applications-related questions can be answered in real time by Varian's NMR applications people. As a matter of policy, Varian provides online support during installation and during the warranty period. If direct access to the Internet is not technically feasible, a high-quality analog telephone line can be used. Varian provides a high-speed modem during the system installation.

**Table 18.** Maximum Air Conditioning Requirements

For standard systems and host workstations.

<i>System</i>	<i>Power (kW)</i>	<i>Surge Current<sup>1</sup> (A)</i>	<i>Power Factor<sup>2</sup></i>	<i>BTU/hr<sup>3</sup></i>
200, 300, 400, 500 MHz standard <sup>4</sup> system	1.7	78	0.925 leading	5800
600 MHz standard system	1.8	78	0.925 leading	6150
750, 800, 900 MHz standard 3-channel system	2.3	78	0.925 leading	7850
host workstation, monitor, peripherals <sup>5</sup>	0.9			3100

1. Decay time <150 ms.

2. Leading and lagging is the phase relationship between voltage and current.

3. Conversion of the unit of heat energy between BTU and the amount of system power is calculated using

1 kWh = 3413 BTU.

4. Measurements are only for the standard acquisition and rf console, which does not share an ac power branch with the host workstation.

5. Measurements are only for the host workstation, which does not share an ac power branch with the acquisition and rf console.

For systems equipped with the following modules, increase the heat output of the standard system by the maximum amounts shown:

<i>System</i>	<i>kW</i>	<i>BTU/hr</i>
SMS autosampler	0.18	615
CP/MAS solids	0.1	340
Wideline module	1.0	3413
CRAMPS/multipulse module	1.0	3413
Complete solids module	1.7	5800
Additional rf channel	0.5	1700
Ultra•nmr shims module	0.75	2600
Performa XYZ PFG module	1.0	3413
Microimaging module	1.5	5120
Solids Accessory cabinet	0.02	68

If internal security policies preclude ready modem or Internet access to the spectrometer, contact Varian's installation department for a list of options that might satisfy security concerns.

## 3.10 Electrostatic Discharges

Electrostatic discharges less than 15 kV generally do not result in any perceivable errors or problems. Discharges greater than 15 kV, however, might result in loss of data and errors perceivable to the operator. Discharges greater 25 kV can cause damage to the equipment.

To prevent electrostatic discharge damage, the system should be installed on vinyl-covered floors and be properly grounded. If carpeting is installed, the carpet should contain only a small percentage of nylon and be installed over antistatic pads. Alternatively, regular use of a good quality antistatic spray can help considerably in alleviating the problem.

Whenever a printed circuit board must be touched or handled, the person should wear grounded wrist straps.

**CAUTION:** Many components in the system contain highly sensitive electronic devices that must be protected from electrostatic discharges by proper floor coverings and grounding practices. A person walking across a nylon carpet or wearing synthetic fabrics can generate an electrostatic charge that can discharge to the next object that is touched. If this happens to be the system, the system components can be damaged. An overly dry atmosphere also tends to create an electrostatic charge. As with any system based on integrated circuits, the system is susceptible to static spikes, both those generated on the power line and those generated in the lab area, that must be suppressed.

## 3.11 Host Workstation Preparation

Varian NMR spectrometers are operated using a host workstation that runs the VnmrJ NMR software

### Magnetic Field Considerations

The host workstation system and magnetic storage media (hard disk, streaming magnetic tape cartridge, etc.) must be located beyond the 5 gauss field of the magnet, so that the magnetic field cannot damage data. See the field plots in [Section 5.2, “Stray Field Plots,” on page 57](#) for typical distances at which various gauss levels exist for particular magnets, but be aware that these distances vary somewhat for each magnet and should be checked after a magnet is installed.

### Required Peripherals

A CD-ROM drive is required to load the operating system and VnmrJ software onto the host workstation. While loading the software remotely is possible, loading the software locally is preferred. Often, the remote computer is password protected and thus requires the presence of the system administrator to enter the password and grant access. Should any troubleshooting or software reloads be required, the process would be complicated by the need for the system administrator.

### Operating System Installation

Host workstations operating either as an NMR acquisition host or as a separate data station require specific setup and configuration for the operating system (OS, including Solaris,

Linux, Macintosh) installation. Varian, Inc. provides instructions for configuring the Host workstation and installing OS software for optimum NMR spectrometer performance.

*If you have purchased your host workstation from Varian, Varian assumes full responsibility and the Varian installation engineer will install both the OS and VnmrJ software.*

*If you have purchased your host workstation from another source, you are responsible for configuring the hardware and installing the OS according to the instructions provided by Varian, Inc. (you can request a free copy through Varian Technical Support or through your local Varian sales and service organization). Installation will not start until the host workstation system is properly configured; however, you are not expected to install the Varian VnmrJ software.*

*There is an exception: If you have purchased a host workstation from a source other than Varian and if you have a knowledge of OS system administration and if that host workstation came with the OS preloaded, it is possible to reconfigure the preloaded OS so that it can be used for VnmrJ operation.*

## Collecting System and Network Information

You can save time by collecting some system and network information before beginning the OS installation.

Use the **Table 19** to record your system information. Each field on the worksheet is described below.

If your system is not connected to a network, you need to know or create only the Host name, root password, and the time zone. If your system is on a network, you need additional information described in the following sections. If unsure, contact your network administrator.

**Table 19.** Preinstallation Worksheet OS Installation

<i>Category</i>	<i>Your Configuration</i>
<b>Host Name</b> Example: <i>mysystem</i> Do not use: <i>inova, inovaauto, gemcon, or wormhole</i>	
<b>Primary Network Interface</b> Use: <i>1e0</i> for 10baseT Ethernet boards; or <i>hme0</i> for Ultras or 10/100baseT Ethernet boards.	
<b>IP Address</b> Use: <i>10.0.0.1</i> for non-networked spectrometers, or your network IP number for all other networked systems.	
<b>Name Service</b> Choices: <i>NIS, NIS+, Other</i> or <i>None</i>	
<b>Domain Name</b> Example: <i>our.domain</i>	
<b>Name Server Host Name</b> Example: <i>ourserver</i>	
<b>Name Server IP Address</b> Example: <i>195.5.2.25</i>	
<b>Subnet Mask</b> Example: <i>255.255.255.0</i>	

## System Configuration Type

You are asked to configure your Sun workstation as one of the following: server, standalone, or dataless client. A *server* is a system that provides network services such as file transfer and storage space. A *standalone* system is a system that contains its own hard disk and bootup files. A *dataless client*, sometimes called diskless client, is a system without its own hard disk and uses an NFS server for the operating system, storage, and other services. For the purposes of VnmrJ, you must install your system as a standalone system.

## Selecting a Host Name

Each computer on a network has a *host name* that uniquely identifies the computer. If you already have a version of UNIX or Linux installed, you can use the command `uname -n` from within a shell to display this information for a host workstation.

Note that VnmrJ reserves the IP names `inova`, `inovaauto`, and `wormhole`. Do not use these names for your host name. When choosing a host name, make sure the name you select is unique within both your local area network and, if applicable, your name service domain.

In many networks, the choice of a host name is left up to the owner of the host workstation (subject to the requirement of uniqueness). A host name can be up to 64 uppercase or lowercase characters. It is strongly recommended that you use all lowercase characters in the host name because some networking software that might be used in other computers on the network could require lowercase host names. Choose a name that starts with a lowercase letter, followed by any combination of lowercase letters, numbers, or hyphens. The name, however, cannot end with a hyphen.

## Obtaining the IP Address

Your host workstation must have a unique Internet Protocol (IP) network address if your Sun workstation is to be attached to a network. Consult your network administrator about the address. If the software is being installed on a host workstation that is already connected to a network, the command `ypcat hosts | grep `uname -n`` can be used to display the IP address of your Sun workstation. Note the use of back quotes ( ``` ) in this command.

If NIS is not enabled, use the command: `cat /etc/hosts | grep uname -n`

One of the IP addresses specified in RFC1597 must be available. These are:

```
10.0.0.x
172.16.0.x
192.168.0.x
```

where *x* is 1 through 4.

## Selecting a Subnet Mask

The subnet mask is a number that is used to split IP addresses into the network (Internet) and host parts. If your site does not use multiple subnets, use the default number; otherwise, consult your network administrator. For a Sun workstation connected to a network, the command `cat /etc/netmasks` can be used.

### *Selecting the Name Service Type*

The name service prompt allows choosing between NIS, NIS+, and none. If you choose NIS or NIS+, you need to enter the host name and the IP address of the computer from which you receive the service. If you choose none, you are not prompted for additional information. Ask your network administrator what name service the network uses.

### *Entering the Host Name and IP Address of the Name Server*

If you select either NIS or NIS+ as the name service type, it is assumed that there is another computer on the network that is the current NIS or NIS+ server. You are asked to enter the host name and IP address of the server that provides the name service. On an existing computer, the server's name can be displayed by entering the command `ypwhich`. The server's IP address and other information can be displayed by entering the command `ypcat hosts | grep `ypwhich``. Again, note the use of back quotes ( ` ).

### *Domain Name*

The domain name is the name assigned to a group of computers that are administered together. All computers in the group (domain) are accessed by the same NIS or NIS+ maps. Your network administrator should be able to provide the domain name. You can also find your domain name by entering the command `domainname`.

## Chapter 4. Installation Supplies

Sections in this chapter:

- 4.1 “Required Installation Supplies and Equipment” this page
- 4.2 “Recommended Installation Supplies and Equipment” page 53
- 4.3 “LC-NMR Equipment, Supplies, and Solvents” page 53

Certain supplies not provided by Varian, such as helium and nitrogen supplies, must be obtained by the customer *before* the Varian installation engineer can start the installation.

### 4.1 Required Installation Supplies and Equipment

The installation engineer will need the following non-Varian supplies and equipment during installation:

- Liquid helium supply
- Liquid nitrogen supply
- Helium gas supply
- Nitrogen gas supply
- Face mask and thermal gloves
- Heat gun
- Nonferromagnetic ladder
- Hoist
- Isopropyl alcohol and acetone

Locating a reliable local source of liquid helium and nitrogen is particularly important. As soon as possible after ordering a system, make arrangements for an initial delivery and an ongoing supply of liquid helium and nitrogen.

## Liquid Helium Supply

To prevent unnecessary loss of the supply, request delivery just prior to the scheduled visit of the Varian installation engineer. **Table 20** lists the amount of liquid helium (LHe) recommended at installation.

**CAUTION:** Specify that supply dewars be made of nonmagnetic materials. A magnetic supply dewar next to the magnet can damage the magnet solenoid. A magnetic supply dewar can also be pulled into the magnet, possibly damaging the magnet or causing the magnet to quench.

The amount of loss due to boiloff as the magnet is cooled varies. An initial LHe supply about 50% more than the amount expected to be necessary for cooling down the magnet is usually adequate; however, an additional supply for delivery on short notice is also advisable should the initial amount be insufficient. **Table 20** shows the quantities recommended.

When ordering LHe for a 200/54 or 300/54 magnet, be sure that the supply dewar has a diameter less than 84 cm (33 in.) (typically a 100-L dewar). This is necessary because these magnets use a rigid transfer tube that must be inserted into the storage dewar and magnet dewar simultaneously without bending. All other magnets use a flexible transfer tube that inserts into most sizes of supply dewars.

**Table 20.** Initial Onsite and Short Notice Liquid Helium Supplies

<i>Magnet/Bore (MHz/mm)</i>	<i>Initial Supply (liters)</i>	<i>Short Notice Supply (liters)</i>
200/54	200	150
200/54 LH235	300	200
200/54 LH365	300	200
200/89	300	200
300/54	200	150
300/54 LH235	300	200
300/54 LH365	300	200
300/89	300	200
400/54	400	200
400/54 LH365	500	200
400/54 AS	500	200
400/89 AS	500	200
500/51	500	200
500/51AS	600	200
500/89	1000	600
600/51	1000	600
600/51AS	1000	600
600/89	1000	600
700/54 AS	2000	1200
750/51	2000	1200
800/63(2.2K)	3000	2000
900/54(2.2K)	16000	5000

## Liquid Nitrogen Supply

**Table 21** lists the recommended amount of liquid nitrogen (LN). LN storage containers suffer a loss of contents from boiloff, so request delivery of the supply just prior to the scheduled visit of the installation engineer. Provide an adaptor for connecting 9 mm (3/8 in.) ID rubber tubing to the LN container.

For low-temperature operation using the variable temperature accessory, a refrigerant is required. Most commonly, this is liquid nitrogen in the VT cooling bucket.

## Helium Gas Supply

**Table 22** lists the recommended number of helium gas cylinders. A regulator must be provided. Each cylinder should hold at least 8000 liters (285 ft<sup>3</sup>). The helium gas must be the highest purity available: no less than 99.995% or U.S. Bureau of Mines Grade A. A *magnetic* helium gas container can be used provided the unit remains outside the 5 gauss limit of the magnet and the cylinder is firmly secured to avoid movement caused by the magnetic field.

## Nitrogen Gas Supply for Magnet Installation

During installation, one cylinder of nitrogen gas is required for precooling the magnet and for transfer of liquid nitrogen. A regulator must be provided. A *magnetic* nitrogen gas container can be used provided the unit remains outside the 5 gauss limit of the magnet and the cylinder is firmly secured to prevent attraction to the magnet.

If the system is equipped with the variable temperature accessory, a nitrogen gas supply is required. If a fixed source is not available, obtain a nitrogen gas cylinder with pressure regulator. The gas must be dry and chemically pure with a flow rate through the pressure of 19 LPM (40 SCFH) at 207 kPa (30 psig). For low-temperature operation, use prepurified grade gas (99.99%, –85°C dew point).

**CAUTION:** To avoid movement caused by magnetic field attraction, helium gas and nitrogen gas cylinders made of *magnetic* material must be kept outside the 5-gauss limit of the magnet and firmly secured.

**Table 21.** Initial Onsite Liquid Nitrogen Supply

<i>Magnet Field (MHz)</i>	<i>Initial Supply (liters)</i>
200/54	130
200/54 LH235 or 365	325
200/89	325
300/54	130
300/54 LH235 or 365	325
300/89	325
400/54	325
400/54 LH365	325
400/54 AS	325
400/89 AS	325
500/51 AS	325
500/89 AS	700
600/51 AS	700
600/89	700
700/54 AS	2500
750/51	1500
800/63 (2.2)	2000
900/54 (2.2)	4500

**Table 22.** Helium Gas Supply

<i>Magnet field (MHz)</i>	<i>Helium gas (cylinders)</i>
200/54	1
200/54 LH235 or 365	2
200/89	2
300/54	2
300/54 LH235 or 365	2
300/89	2
400/54	2
400/54 LH365	2
400/54 AS	2
400/89 AS	2
500/51 AS	2
500/89 AS	3
600/51 AS	3
600/89	3
700/54 AS	5
750/51	5
800/63 (2.2)	5
900/54 (2.2)	5

## Face Mask and Thermal Gloves

If cryogenic helium or nitrogen contact living tissue, a serious injury (similar to a burn) can occur. Order appropriate safety coverings for use during dewar servicing, including a mask that protects the face completely and a loose-fitting pair of thermal gloves.

**WARNING:** Avoid helium or liquid nitrogen contact with any part of the body. If liquid helium or nitrogen contact living tissue, a *serious injury* (similar to a burn) can occur. Never place your head over the helium and nitrogen exit tubes on top of the magnet. If helium or nitrogen contacts the body, seek medical attention, especially if the skin is blistered or the eyes are affected.

## Heat Gun

Acquire a 1600 W heat gun and a heavy-duty extension cord for thawing ice accumulation and drying out moisture on dewar servicing equipment.

**CAUTION:** These heat guns contain ferrous magnetic materials.

## Nonferromagnetic Ladder

Acquire a 180cm (6 ft) nonferromagnetic ladder for reaching the top of the dewar while inserting and removing the helium transfer tube. The ladder should be sturdy and self-supporting with rubber feet. A somewhat taller ladder 250–300 cm (8–10 ft) is recommended for 750- and 800-MHz magnets.

## Hoist

A hoist must be available to remove the magnet from the crate, assemble it, and move it into place. The capacity of the hoist depends on the weight of the magnet being installed. [Table 5 on page 24](#) specifies magnet weights. Allow a safety factor of at least 100% above the weight shown. Be sure adequate space is available for bringing the hoist and magnet in through the lab door.

**WARNING:** Death of serious injury may result if the magnet is lifted with improperly assembled or improperly rated equipment.

The hoist can be a chain hoist suspended from a moveable mechanism, such as an A-frame, or it can be permanently fixed above the area designated for the magnet, such as a beam. A vertical lifting device is required for magnets with antivibration legs; this vertical lifting device would eliminate the need for a “cherry picker” type device. Consult your plant facilities department or Varian representative to ensure that facilities are available.

## Isopropyl Alcohol and Acetone Solvents

Obtain 1 pint (500 cm<sup>3</sup>) each of isopropyl alcohol and acetone. These solvents are needed to clean the magnet parts before assembly. Acetone should never be used for general cleaning as it can damage some plastics and paints.

## 4.2 Recommended Installation Supplies and Equipment

In addition to the required installation supplies and equipment, the following items are recommended:

- Cryogenic equipment rack
- Electrical power surge protector
- Monitor degaussing coil

### Cryogenic Equipment Rack

Various items are used around the magnet for routine maintenance and handling, including a helium transfer tube, a flutter tube, Tygon tubing, and stingers. To protect the cryogenic equipment from damage and to keep it conveniently available, provide a rack to hold the items. A 1.2 m × 2.4 m (4 ft × 8 ft) peg board hung on a laboratory wall, with wood or plastic pegs, works very well.

### Electrical Power Surge Protector

To protect the delicate electrical components of the workstation (monitor, disk drive unit, CPU base, etc.), a good quality surge protector should be inserted in the power circuit serving the components. A single surge protector with six outlets should suffice if the components are located relatively close to one another. Contact an electronic professional for advice on quality surge protection in your area. If a UPS is to be used for line conditioning, a surge protector is unnecessary.

### Monitor Degaussing Coil

The workstation monitor can gradually become somewhat magnetized due to its proximity to the magnet. This condition can be corrected with a degaussing coil. If the host workstation system is to be located near the edge of the 1–2 gauss stray field of the magnet, the degaussing coil is a necessity. For example, GC Electronics model 9317 (1801 Morgan St., Rockford Il., 61102, (815) 968-9661).

## 4.3 LC-NMR Equipment, Supplies, and Solvents

You must have the following equipment, samples, and solvents on hand before the LC-NMR accessory is installed:

- A nonmagnetic table (at least 3 ft by 4 ft) to hold the LC hardware.
- Either gas cylinder of helium, outfitted with 0.25-inch OD Teflon tubing with aerator (this will be used for sparging the acetonitrile solvent), or the necessary degassing equipment. Do not use an aspirator.
- At least 300 mL of D<sub>2</sub>O, 99.8 atom percent or better.
- At least 100 mL of acetone-d<sub>6</sub>.
- At least 300 mL of OmniSolv brand acetonitrile (EM Science part no. AX014-l).
- Research grade sucrose.
- At least three, 100-mL volumetric flasks for preparing standard samples.
- An appropriate waste container for HPLC effluent. The cover of the container must have a hole in the top of about 2 mm diameter. The hole is used for the outlet of the LC-NMR Microflow probe.
- Air supply for the pneumatic valve.



## Chapter 5. Stray Magnetic Fields

Sections in this chapter:

- 5.1 “Safety Hazards of Strong Magnetic Fields” this page
- 5.2 “Stray Field Plots” page 57
- 5.3 “Posting Requirements for Magnetic Field Warning Signs” page 71

The magnetic field is typically the biggest concern when planning for an NMR system. This chapter contains magnetic field safety information and stray field plots.

### 5.1 Safety Hazards of Strong Magnetic Fields

The potential safety hazards of strong magnetic fields for devices such as certain pacemakers must be understood and planned for. A set of plots indicating the magnitude of the stray fields for each type of magnet is included in [Section 5.2, “Stray Field Plots,” on page 57](#). These plots show typical levels of stray field. Actual levels may vary and should be checked after a particular magnet has been installed.

**WARNING:** Cardiac pacemaker wearers *must* remain outside the 5-gauss perimeter from the magnet until safety is clearly established. An NMR superconducting magnet generates strong magnetic and electromagnetic fields that can inhibit operation of some cardiac pacemakers, which could result in death or serious injury to the user. Consult the pacemaker user’s manual, contact the manufacturer, or confer with a physician to determine the effect on a specific pacemaker. Varian provides signs with each system to warn pacemaker wearers of this hazard. Post the signs according to [Section 5.3, “Posting Requirements for Magnetic Field Warning Signs,” on page 71](#).

#### Pacemakers

Cardiac pacemaker wearers must not enter a zone that would subject a cardiac pacemaker to a magnetic intensity that could cause adverse effects. In some instances, this zone might include space on the floors directly above and below the magnet. For assistance in determining the effect of a system on pacemaker, consult the pacemaker user’s manual, contact the pacemaker manufacturer, or confer with a physician to determine the effect on a specific pacemaker. Actual levels vary and should be checked after a particular magnet has been installed.

## Magnetic Field Exposure

NMR workers are often exposed to high levels of static magnetic fields. At this time, no conclusive scientific evidence exists indicating adverse health effects at current exposure levels. Current exposure levels are generally indicated as levels equal to or less than those in [Table 23](#).

Although some studies suggest a link between magnetic field exposure and adverse reproductive effects, the body of medical data available is not clear enough to draw any firm conclusions regarding risks to pregnancy. In other words, static magnetic field associated with the NMR spectrometer magnets are not considered by the scientific community at this time to comprise a risk to pregnancy or a reproductive hazard.

An article by the American Conference of Governmental Industrial Hygienists (ACGIH) entitled “Threshold Limit Values and Biological Exposure Indices, 5th ed.” states the following:

“TLVs [Threshold Limit Values] refer to static magnetic flux densities to which it is believed that nearly all workers may be repeatedly exposed day after day without adverse health effects. These values should be used as guides in the control of exposure to static magnetic fields and should not be regarded as a fine line between safe and dangerous levels.

“Routine occupational exposures should not exceed 60 milliteslas (mT)—equivalent to 600 gauss—whole body or 600 mT (6000 gauss) to the extremities on a daily [8

**Table 23.** Stray Field Data for Oxford Magnets

Magnet Type (MHz/mm)	Radial Distance (cm)			Axial Distance (cm)			Base to CL (cm)	Magnet Outside to CL (cm)
	0.6 kG	6 kG	20 kG	0.6 kG	6 kG	20 kG		
900/54	168	78	52	213	99	66	74.5 ±0.5	87.5
800/63 (2.2K)	129	52	9	171	84	59	57.6 ±0.3	58.4
750/51	115	50	32	155	76	53	54.6 ±0.5	58.4
700/54 AS	115	50	32	<i>a</i>	<i>a</i>	<i>a</i>	54.6 ±0.5	58.4
600/89	70	<i>a</i>	<i>a</i>	105	55	41	46.5	36.2
600/51 AS	<i>a</i>	<i>a</i>	<i>a</i>	64	41	<i>b</i>	39.1	46.0
500/89 AS	<i>a</i>	<i>a</i>	<i>a</i>	74	44	<i>b</i>	39.1	46.0
500/89	70	<i>a</i>	<i>a</i>	96	48	35	44.0	45.9
500/51	57	<i>a</i>	<i>a</i>	79	41	<i>b</i>	39.1	36.2
500/51 AS	<i>a</i>	<i>a</i>	<i>a</i>	54	34	<i>b</i>	39.1	36.2
400/89	56	<i>a</i>	<i>a</i>	81	42	<i>b</i>	38.5	36.2
400/89 AS	<i>a</i>	<i>a</i>	<i>a</i>	63	37	<i>b</i>	36.3	36.2
400/54 AS	<i>a</i>	<i>a</i>	<i>a</i>	48	31	<i>b</i>	36.3	36.2
400/54	39	<i>a</i>	<i>a</i>	59	<i>b</i>	<i>b</i>	33.2	36.2
300/89	40	<i>a</i>	<i>a</i>	59	<i>b</i>	<i>b</i>	35.7	36.2
200/89	<i>a</i>	<i>a</i>	<i>a</i>	56	<i>b</i>	<i>b</i>	35.1	36.2
300/54	<i>a</i>	<i>a</i>	<i>a</i>	38	<i>b</i>	<i>b</i>	23.9	28.0
200/54	<i>a</i>	<i>a</i>	<i>a</i>	33	<i>b</i>	<i>b</i>	23.9	28.0

- a. Where no radial position is given, the point is within the cryostat body.  
 b. The axial point is in the cryostat bore. Compare with the magnet centerline (CL) distance.

hour], time-weighted average basis. A flux density of 2 teslas (20,000 gauss) is recommended as a ceiling value.”

## 5.2 Stray Field Plots

This section shows typical stray field data and plots for each magnet. The values are typical but may vary between individual magnets. Gauss levels should be checked after a particular magnet has been installed. The values in [Table 24](#) were provided by Oxford technical documentation. [Table 25](#) lists the distance from the magnet centerline to the floor for high-field magnets.

**Table 24.** Stray Field Data for NMR Magnet Systems

<i>Magnet Systems (MHz/mm)</i>	<i>(Tesla)</i>	<i>Axial Distance from Magnet Center Line</i>			<i>Radial Distance from Magnet Center Line</i>		
		<i>5-gauss (m)</i>	<i>10-gauss (m)</i>	<i>25-gauss (m)</i>	<i>5-gauss (m)</i>	<i>10-gauss (m)</i>	<i>25-gauss (m)</i>
200/54	4.69	1.75	1.45	1.05	1.50	1.20	0.90
200/89	4.69	2.65	2.05	1.49	2.00	1.60	1.15
300/54	7.04	2.20	1.75	1.26	1.70	1.30	0.97
300/89	7.04	2.75	2.20	1.63	2.20	1.75	1.26
400/54	9.39	2.80	2.24	1.65	2.20	1.76	1.29
400/54 AS	9.39	1.50	1.25	0.90	1.00	0.80	0.60
400/89	9.39	3.80	3.00	2.21	3.05	2.40	1.74
400/89 AS	9.39	1.8	1.5	1.17	1.03	.80	0.74
500/51	11.74	3.50	2.70	2.00	2.75	2.20	1.60
500/51 AS	11.74	1.80	1.50	1.10	1.30	1.00	0.70
500/89	11.74	4.50	3.55	2.60	3.55	2.80	2.10
500/89 AS	11.74	2.5	1.9	1.50	1.75	1.4	0.96
600/51	14.09	4.00	3.17	2.34	3.17	2.52	1.86
600/51 AS	14.09	2.50	1.90	1.40	1.75	1.40	0.90
600/89	14.09	5.00	3.97	2.92	3.95	3.14	2.32
700/54 AS	16.44	3.5	2.80	2.00	2.5	1.75	1.00
750/51	17.63	7.60	6.04	4.45	6.1	4.79	3.53
800/63 (4.2K)	18.81	8.69	6.35	4.68	6.89	5.00	3.69
800/63 (2.2K)	18.81	7.6	6.0	4.41	6.0	4.75	3.51
900/54 (2.2K)	21.1	10.5	8.35	5.80	8.30	6.60	4.60

**Table 25.** Magnet Centerline to Floor

<i>Magnet Systems (MHz/mm)</i>	<i>Distance From Magnet Centerline to Floor (m)</i>
200/54 ALOX	0.78
200 Type 3	1.04
300/54 ALOX	0.78
300 Type 3	1.1
400/54, 400/89	1.2
400/54 AS	1.1
400/89 AS	1.145
500/51 AS, 500/89AS	1.2
600/51 AS	1.2
600/89	1.23
700/54 AS	1.34
750/51	1.37
800/63	1.37
900/54	1.845

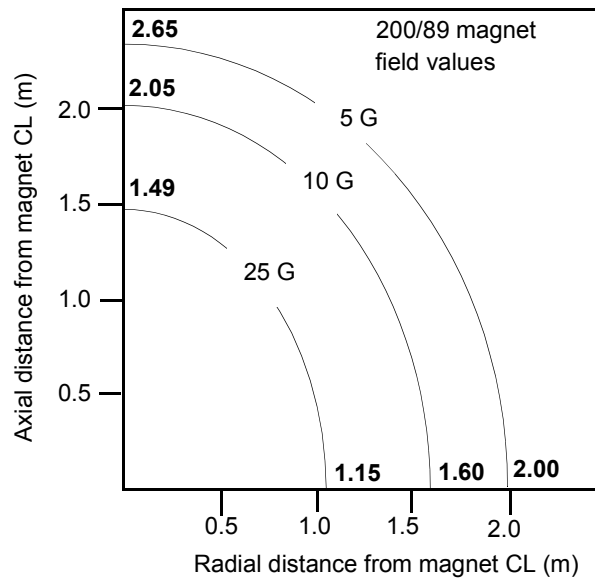
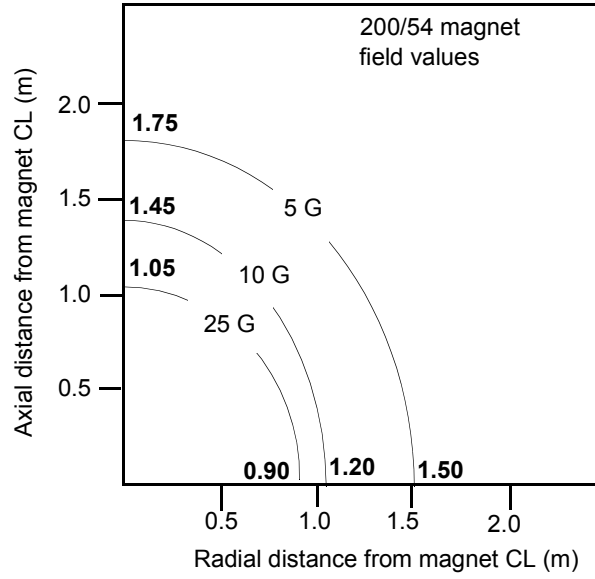

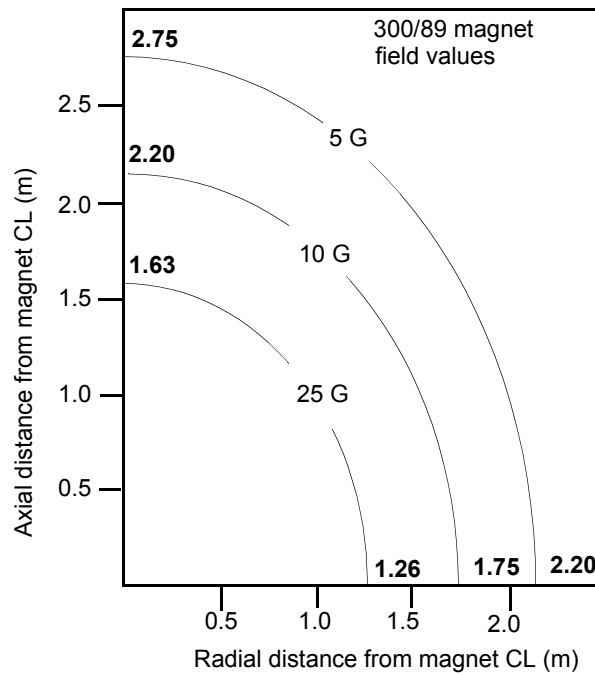
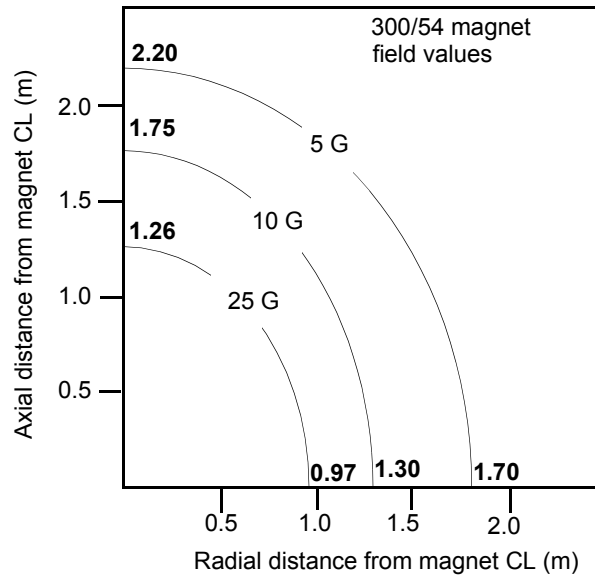

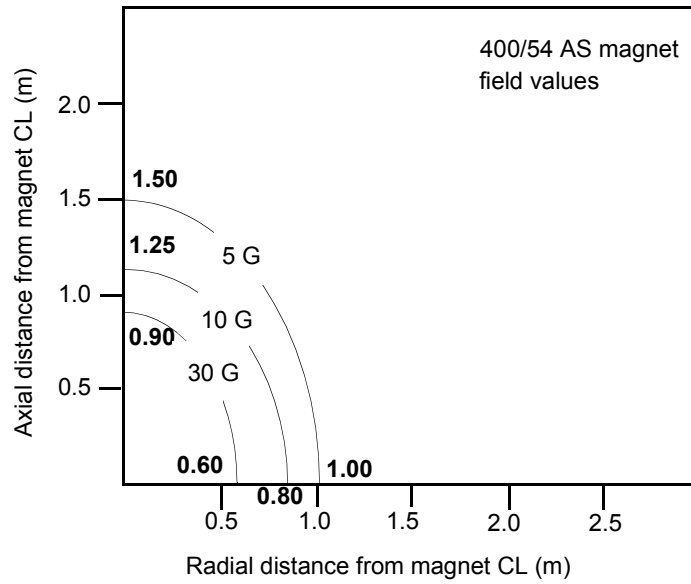
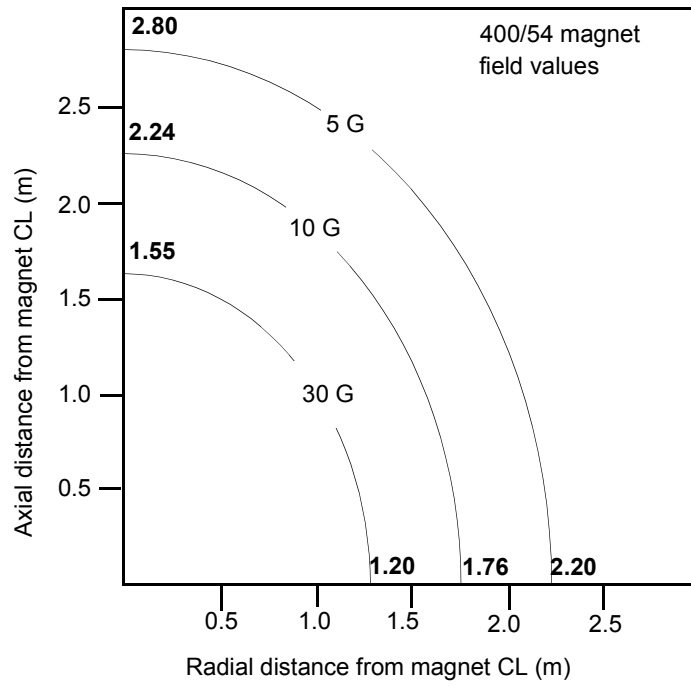

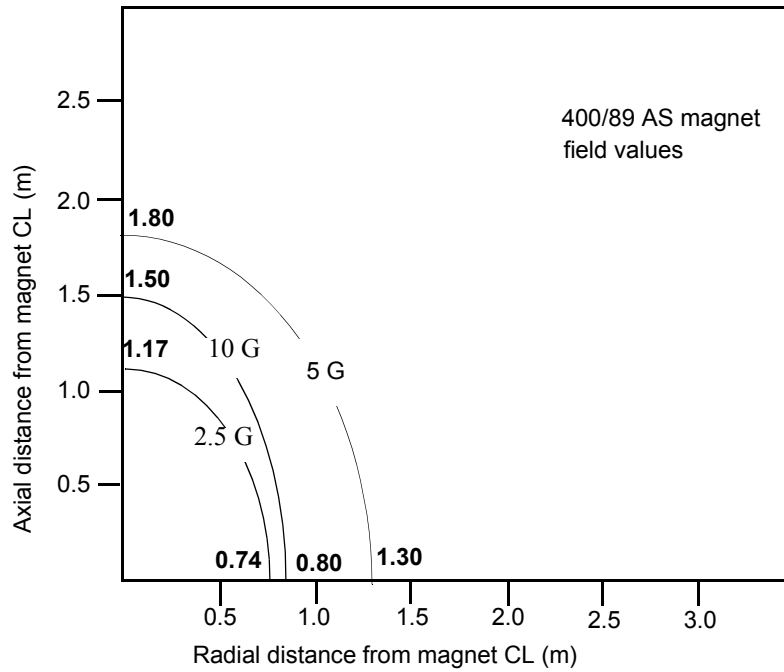
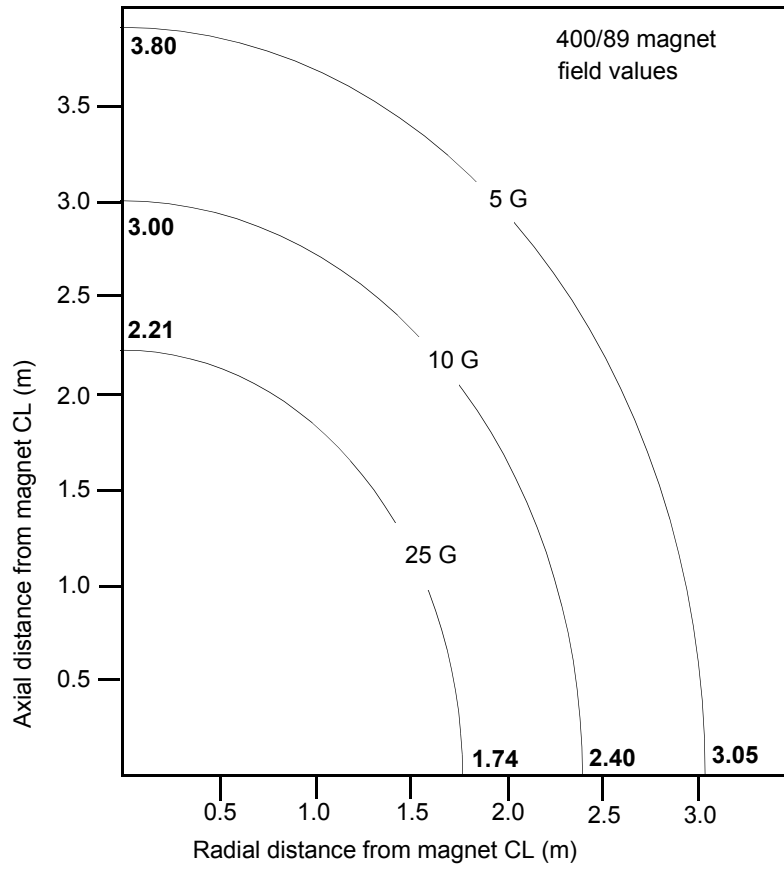

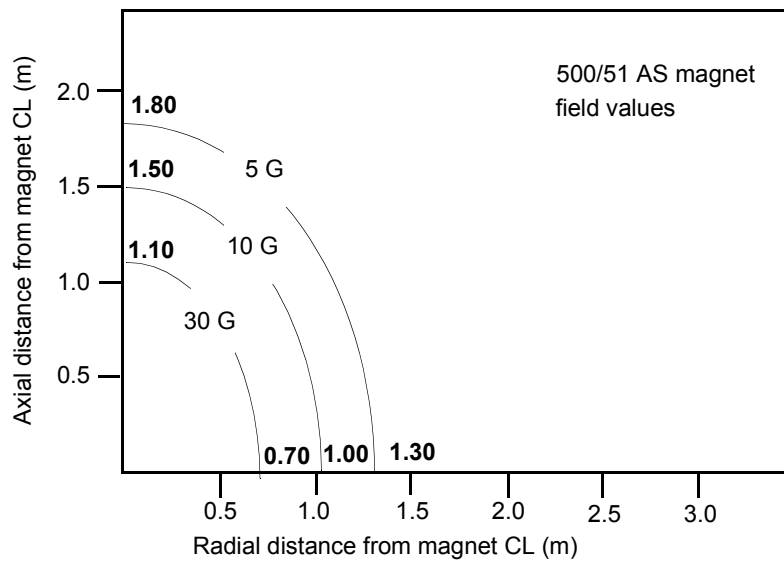
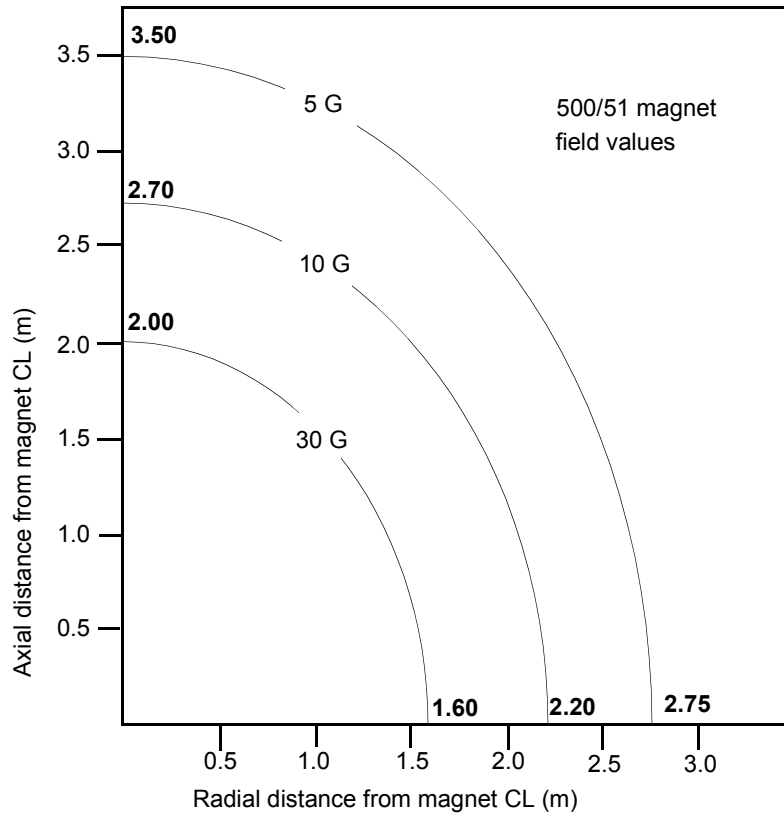

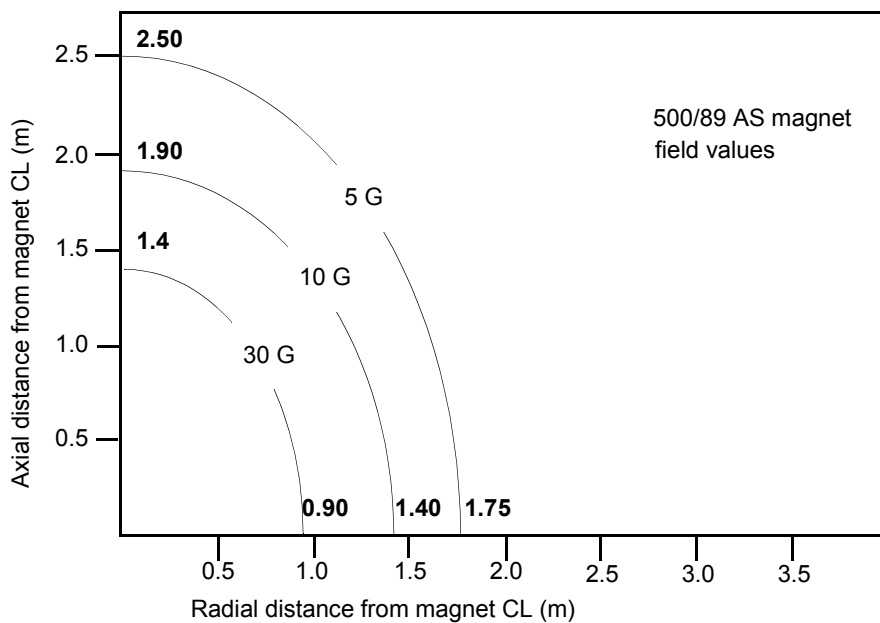
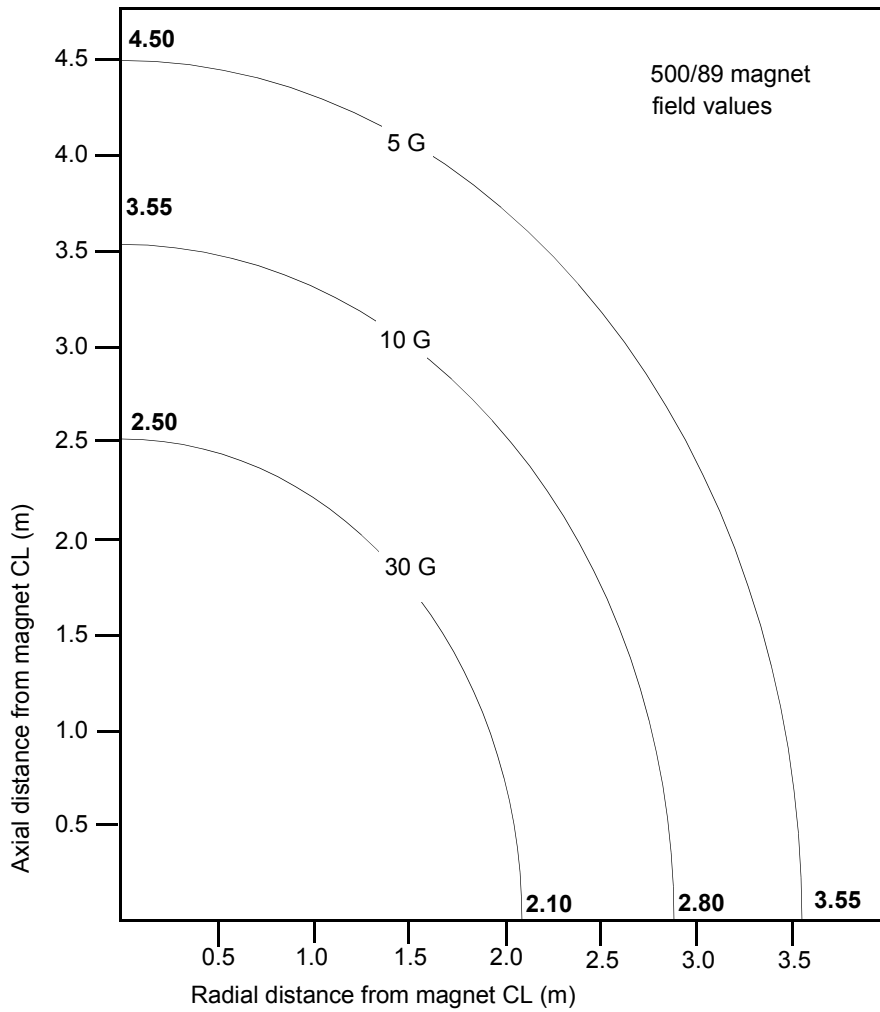

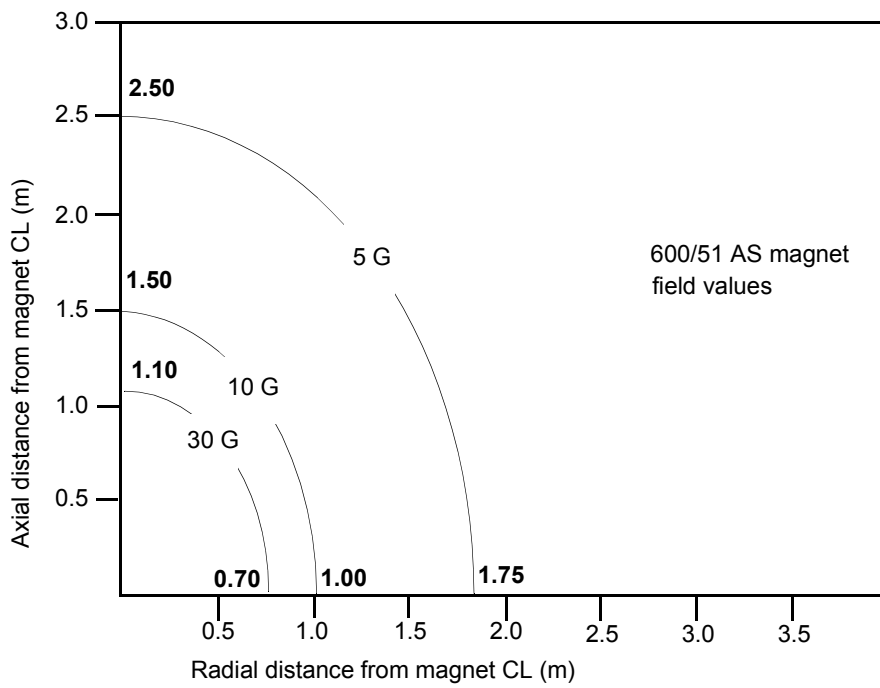
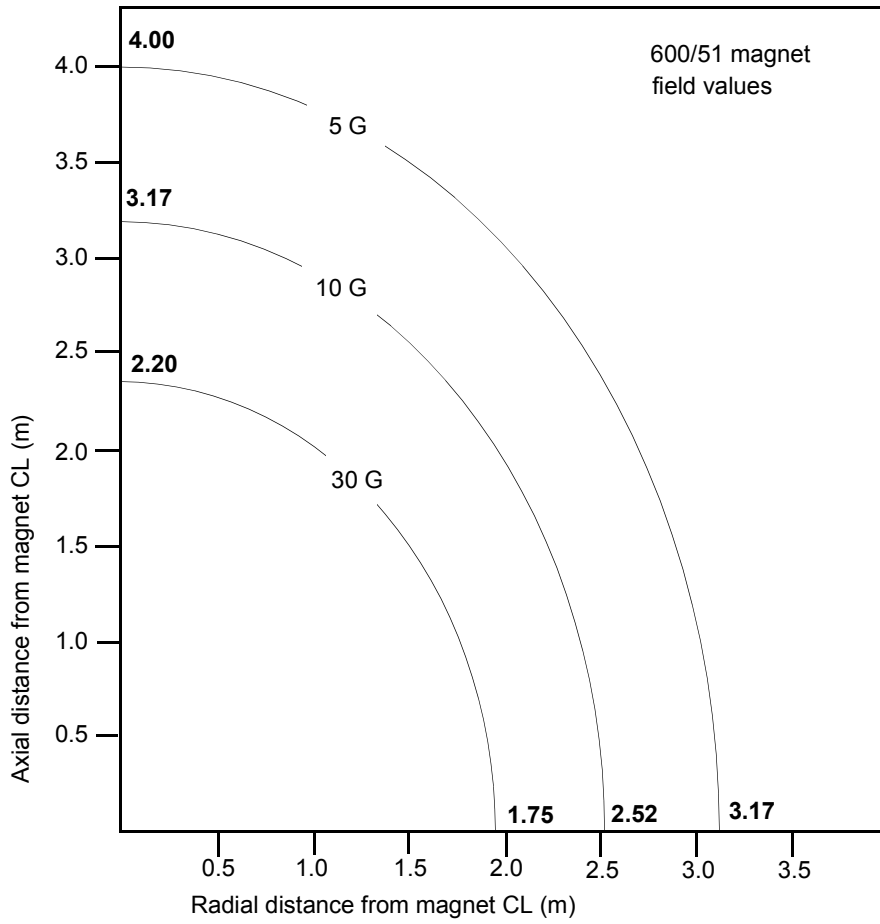

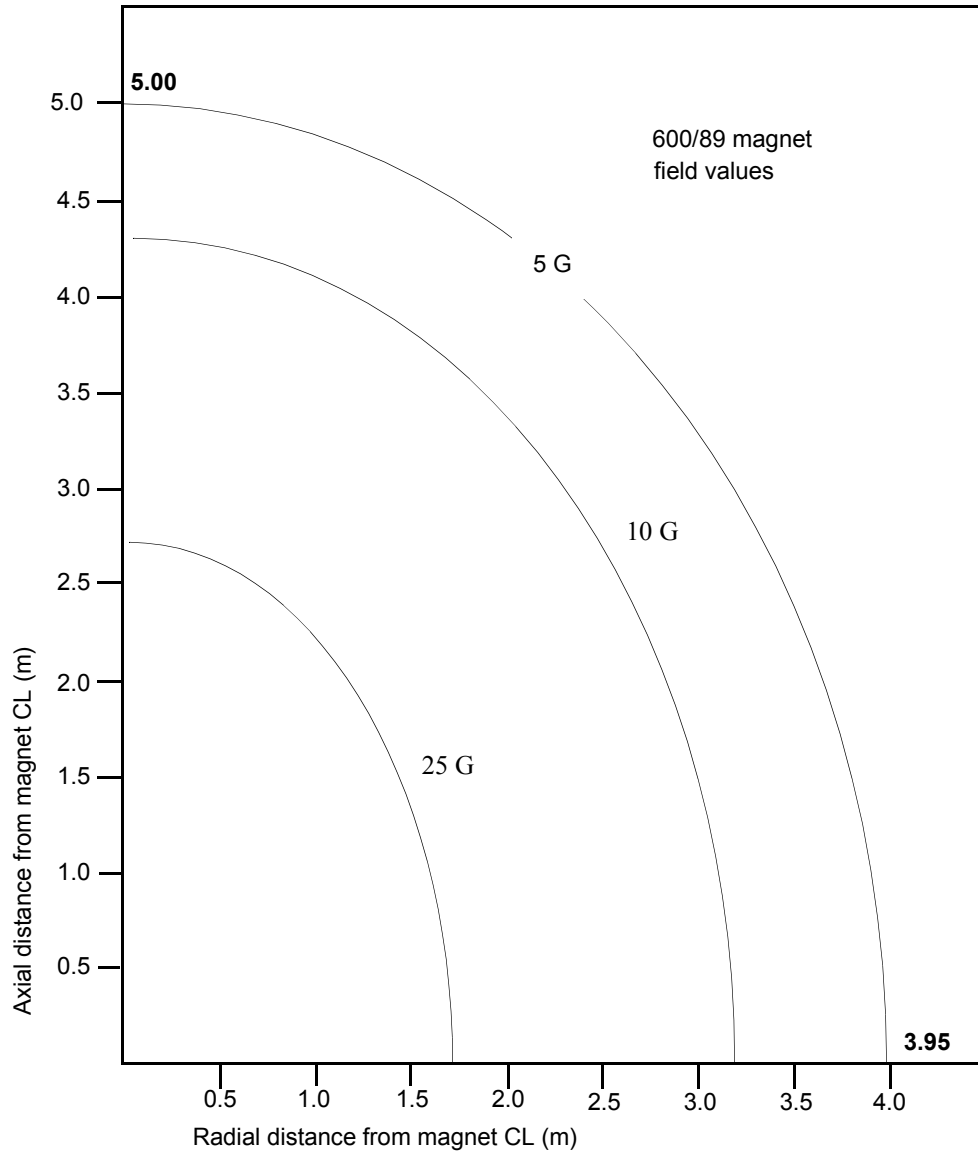

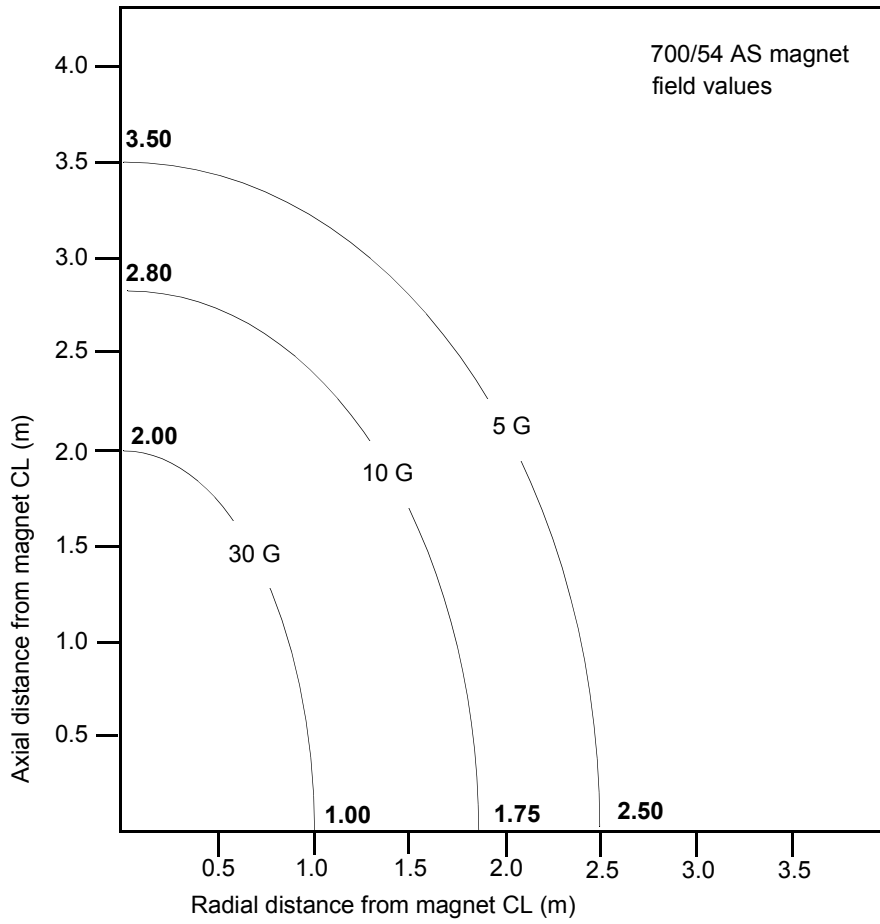

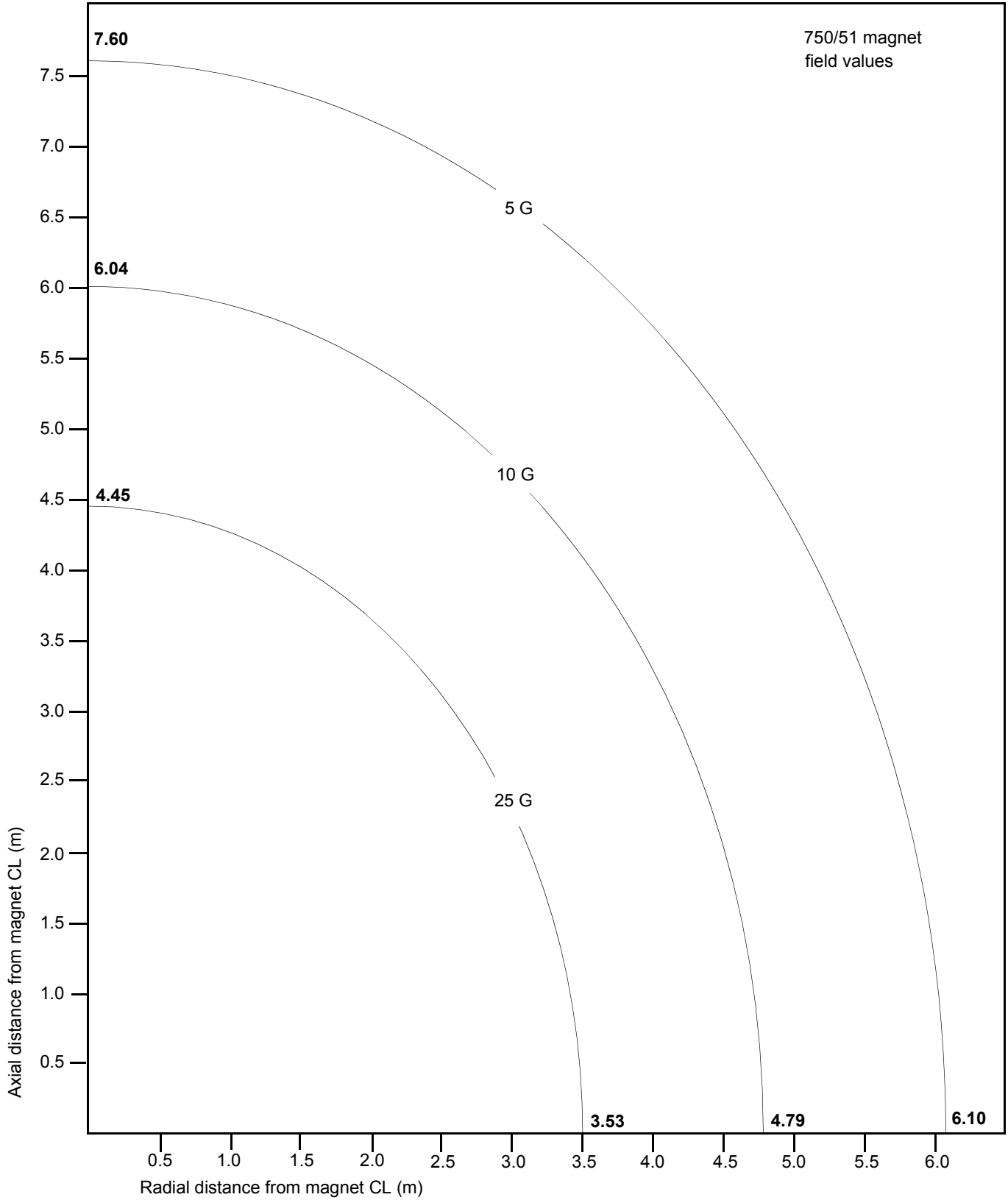

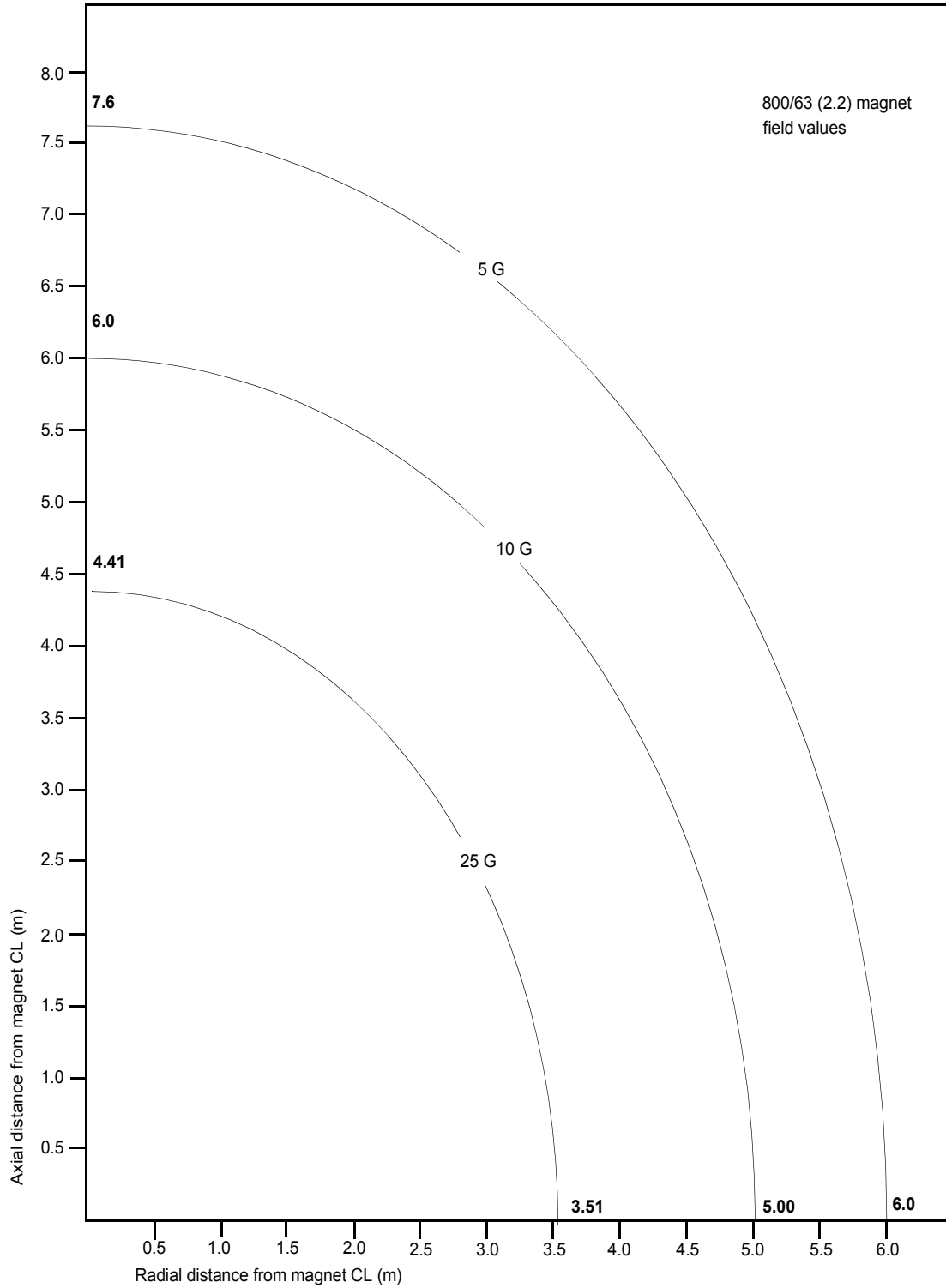

### 900/54 STRAY FIELD

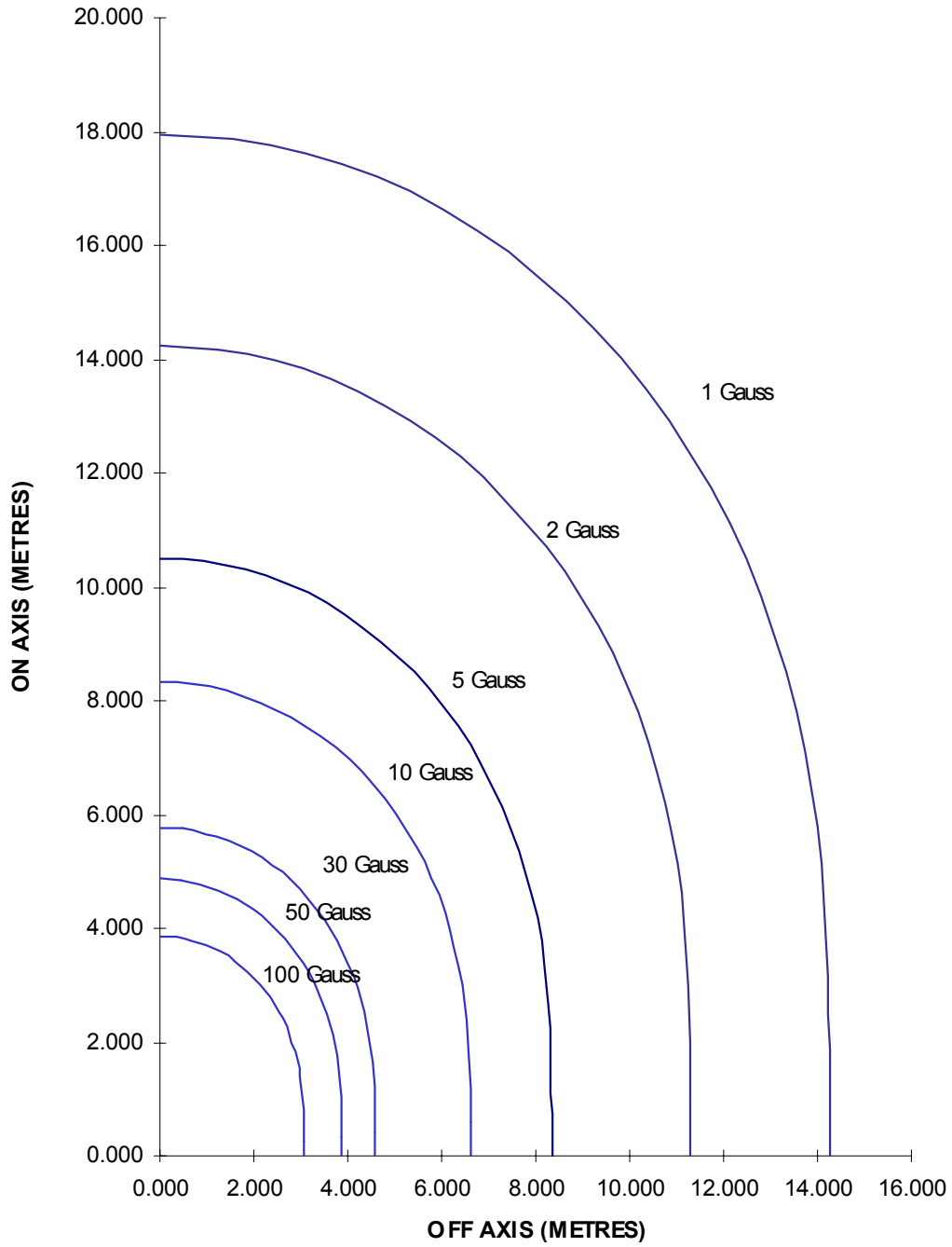

## 5.3 Posting Requirements for Magnetic Field Warning Signs

The strong magnetic fields that surround a superconducting magnet are capable of causing death or serious injury to individuals with implanted or attached medical devices such as pacemakers or prosthetic parts. Such fields can also suddenly pull nearby magnetic tools, equipment, and dewars into the magnet body with considerable force, which could cause personal injury or serious damage. Moreover, strong magnetic fields can erase magnetic media such as tapes and floppy disks, disable the information stored on the magnetic strip of automated teller machine (ATM) and credit cards, and damage some watches.

To warn of the presence and hazard of strong magnetic fields, the customer is responsible for posting clearly visible signs warning of magnetic field hazards. This responsibility includes measuring stray fields with a gaussmeter.

Radio-frequency emissions may also pose a danger to some individuals. The rf emission levels from Varian NMR equipment have been measured and compared to the IEEE/ANSI C95.1-1991 standard. For further information, refer to the *RF Environment* section of the *Installation Planning Guide*.

### Warning Signs

Varian provides signs to help customers meet this posting responsibility. These signs *must* be posted according to the following requirements *before the magnet is energized*:

1. *10-gauss warning signs (Figure 10)* – Post along the 10-gauss perimeter of the magnet so that a sign can be easily seen by any person about to enter the 10-gauss field from any direction. Refer to the manuals supplied with the magnet for the size of a typical 10-gauss stray field. Check this gauss level after the magnet is installed. Note that the stray field may extend vertically to adjacent floors, and additional signs may be needed there. A sign is not required if the 10-gauss field extends less than 30 cm (12 in.) beyond a permanent wall or less than 61 cm (24 in.) beyond the floor above the magnet.
2. *5-gauss warning signs (Figure 11)* – Post along the 5-gauss perimeter of the magnet so that a sign can be easily seen by any person about to enter the 5-gauss field from any direction. Refer to the manuals supplied with the magnet for the size of a typical 5-gauss stray field. Check this gauss level after the magnet is installed. Note that the stray field may extend vertically to adjacent floors, and additional signs may be needed there.

- Magnet area danger signs (Figure 12) – Post at each entrance to the magnet area. Be sure each sign is outside the 5-gauss perimeter.

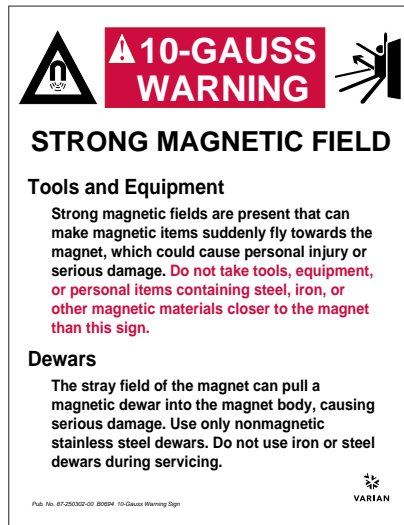

Figure 10. 10-Gauss Warning Sign

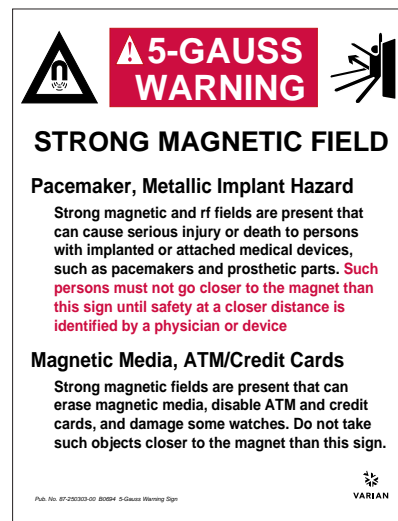

Figure 11. 5-Gauss Warning Sign

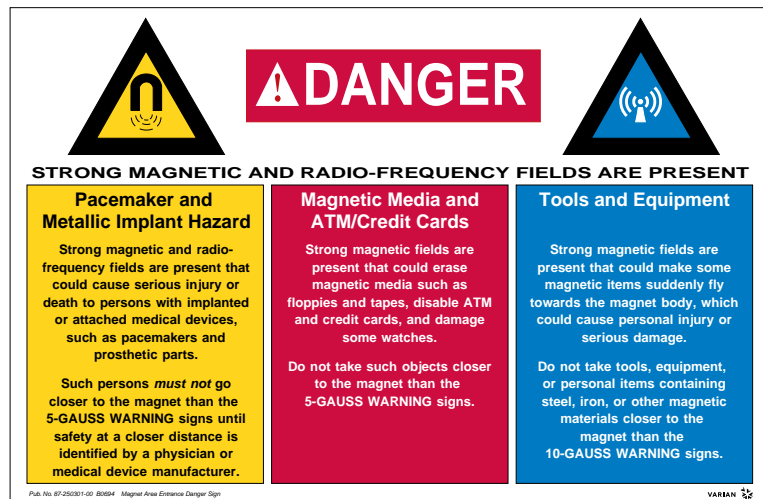

Figure 12. Magnet Area Danger Sign

Stray magnetic fields can reach beyond the published distances when two or more magnetic fields intersect or when the field extends over large ferromagnetic masses or structures (steel doors, steel construction beams, etc.). In this case, the customer *must* measure the stray field using a gaussmeter to determine how the 5- and 10-gauss fields are altered (contact a scientific instrumentation supplier for information on acquiring a gaussmeter).

You can request additional signs from Varian by telephoning 1-800-356-4437 in the United States or by contacting your local Varian office in other countries.

## Chapter 6. System Cable Lengths and Room Layouts

Sections in this chapter:

- 6.1 “System Cable Lengths” this page
- 6.2 “NMR Room Layouts” page 75

This chapter contains information to help in arranging the NMR room.

### 6.1 System Cable Lengths

This section provides details about various cable lengths. Cable lengths limit the distance between the components of the NMR system.

#### RF Cable Harness Between the Magnet RF Front End and Console

For 200/54 and 300/54 magnets, the minimum distance from the nearest edge of the closest cabinet to the centerline of the magnet is 1.5 m (5 ft). **Figure 13** shows a rear view that is not drawn to scale.

For 200/89, 300/89, 400–800 magnets, this distance is 3 m (10 ft), the maximum length of the cable.

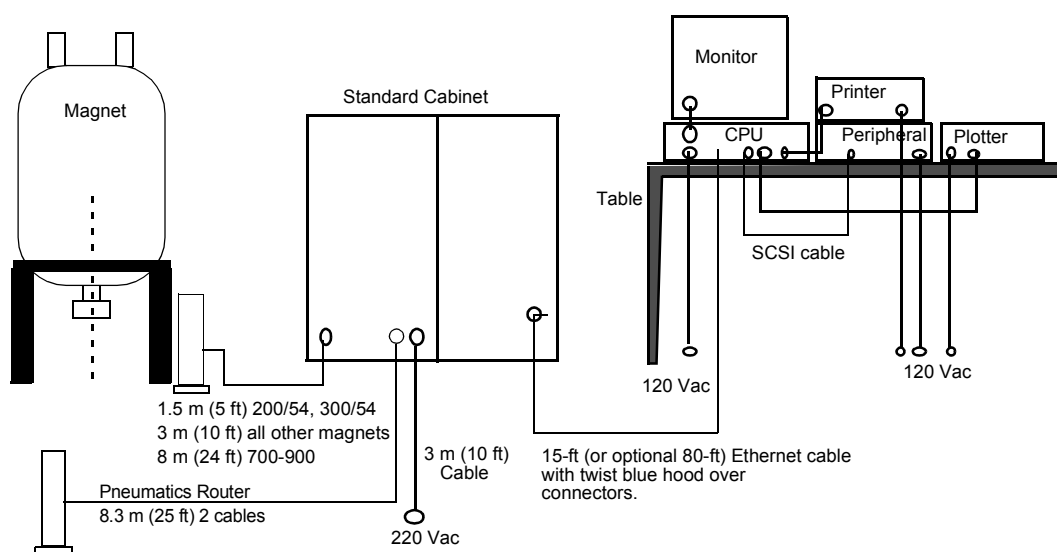

**Figure 13.** Cable Lengths for 200–500-MHz Systems without Options

For 500-, 600-, 700-, 750-, and 800-MHz systems and 300- and 400-MHz systems with the solids cabinet, the minimum distance from the centerline of the magnet to the edge of the nearest cabinet is the maximum length of the cable, which is 3 m (10 ft). A cable from the imaging cabinet to the magnet passes on the other side (front) of the cabinets and is not shown here. A gap of 15 cm (6 in.) is left between the standard cabinet and the options cabinets.

Figure 14 shows a rear view that is not drawn to scale.

### Pneumatics Router

For all magnets, the Pneumatics Router can be mounted on the wall near the gas source or located near or on the console or close to the magnet. Locate the router within 8.3 m (25 ft) of the console. Locate the Pneumatics Router outside the 100 gauss field of the magnet.

### Ethernet Cable Between Console and Host Computer

The Ethernet cable between the NMR console and the host only connects to the second Ethernet board on the host, never to the first Ethernet board. The Ethernet cable runs from the Console Interface panel on the back of the console.

- No. 00-968378-00 is 1.8 m (6 ft) and, therefore, limits the distance that the shim power supply can be from the rf cabinet.
- The distance from the shim power supply to a source of power should be within 1.5 m (5 ft) because the length of the power cord on the shim power supply is 1.5 m (5 ft).
- The distance between the shim power supply and the shim tube, which is installed in the magnet bore, must be less than or equal to 5.2 m (17 ft).
- The interface box must be within 2.4 m (8 ft) of the shim power supply and should be situated next to the Sun host computer to facilitate interactive shimming and locking.

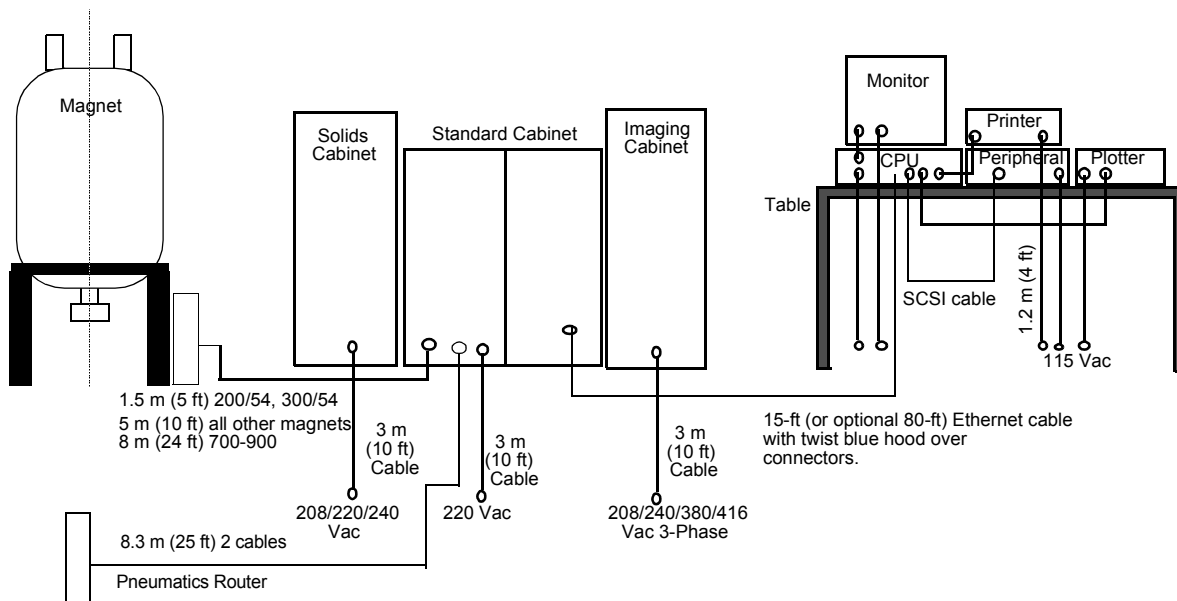

Figure 14. Cable Lengths for High-Field Systems and Systems with Options

## 6.2 NMR Room Layouts

This section provides some suggested NMR room layouts. The illustrations in this section are drawn approximately to scale. When designing room layouts, be sure to account for horizontal (radial) stray fields that can extend beyond the walls and vertical (axial) stray fields that can extend above the ceiling and below the floor. Refer to [Section 5.2, “Stray Field Plots,”](#) on page 57 for actual stray field plots for your magnet.

### Minimum Space for a 300/54 System Without Options

Room dimensions are about 3.6 m × 3.3 m (12 ft × 10.7 ft). The cabinet is 111 cm × 78 cm (44 in. × 31 in.). Typical table size is 183 cm × 76 cm (72 in. × 30 in.). The magnet is 69 cm × 69 cm (27 in. × 27 in.).

If space permits, the larger arrangements shown in subsequent layouts in this appendix are recommended.

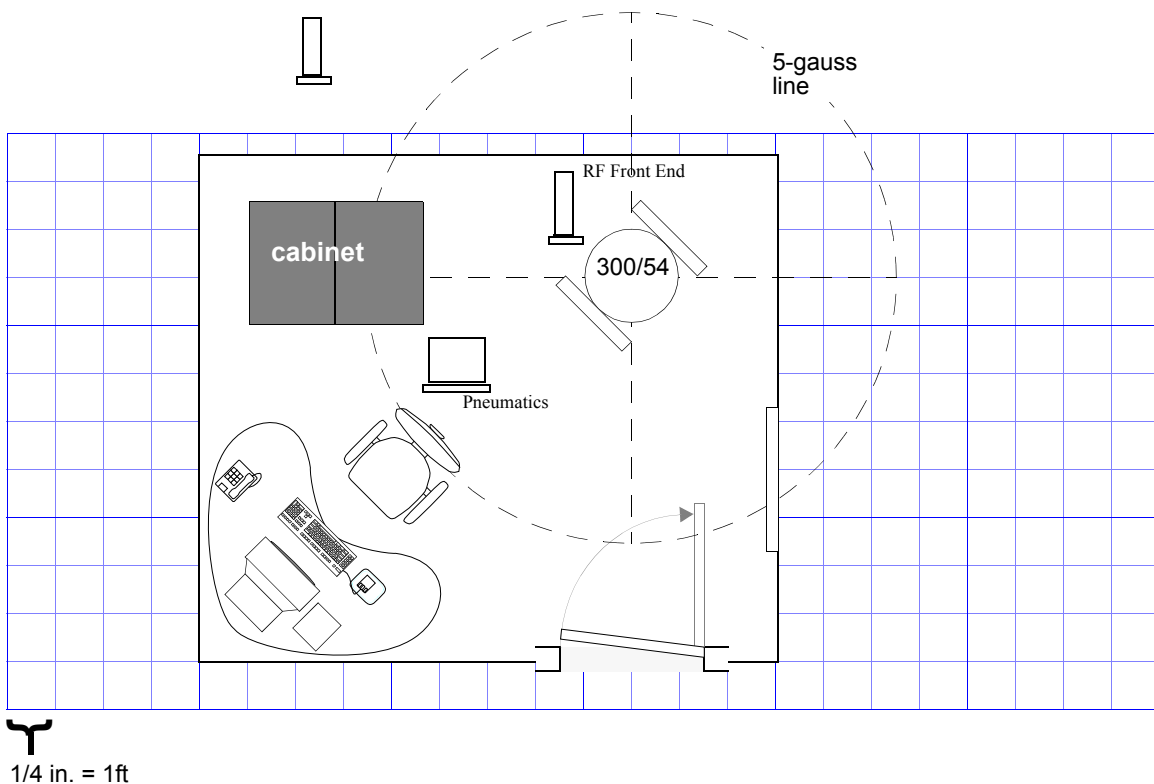

### Standard Space for a 300/54 System Without Options

The room dimensions are about 4.4 m × 4.6 m (14.5 ft × 15 ft). This arrangement provides comfortable access for operator and service personnel. The cabinet is 111 cm × 78 cm (44 in. × 31 in.). Typical table size is 183 cm × 76 cm (72 in. × 30 in.). The magnet is 69 cm × 69 cm (27 in. × 27 in.).

A distance of 1 m (3 ft) should be maintained around the standard cabinet.

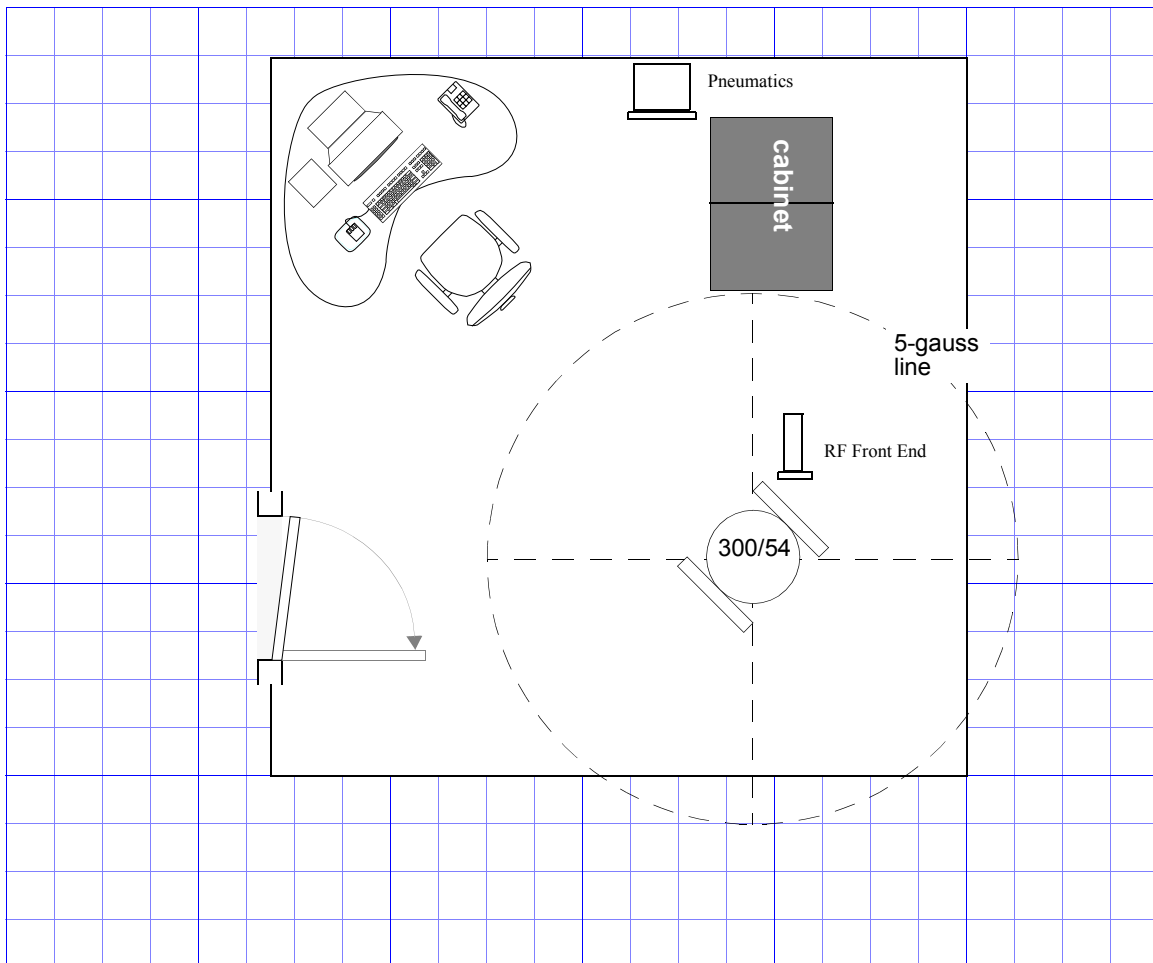

 1/4 in. = 1ft

### Recommended Space for a 300/54 System With Autosampler

The room dimensions are about 4.4 m × 5.5 m (14.5 ft × 18.2 ft). The cabinet is 111 cm × 78 cm (44 in. × 31 in.). Typical NMR table size is 183 cm × 76 cm (72 in. × 30 in.). The magnet is 69 cm × 69 cm (27 in. × 27 in.). A distance of 1 m (3 ft) should be maintained around the standard cabinet.

The SMS autosampler is about 79 cm × 79 cm (36 in. × 36 in.). The following illustrations show the preferred orientation of the SMS table to the magnet. Refer to the Sample Management Systems manual for details about sample changers.

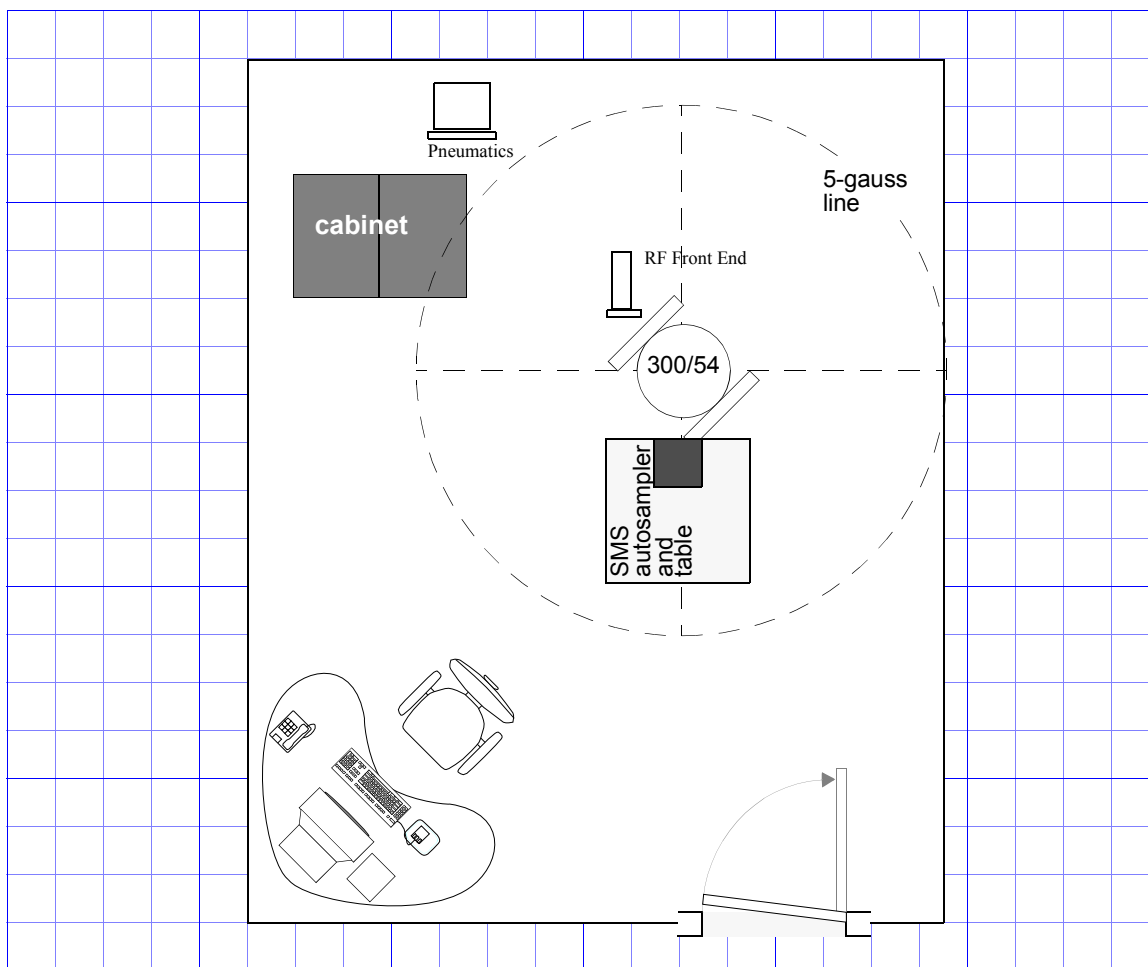
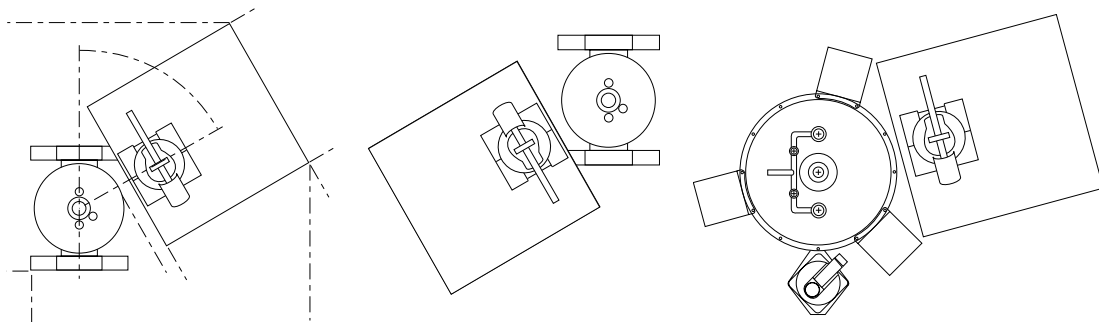

1/4 in. = 1ft

### Minimum Space for a 300/89 System With Solids and Microimaging

The room dimensions are about 4.4 m × 5.5 m (14.5 ft × 18.2 ft). The cabinet is 111 cm × 78 cm (44 in. × 31 in.). The imaging and high-power solids cabinets are 55 cm × 78 cm (22 in. × 31 in.) each. Typical table size is 183 cm × 76 cm (72 in. × 30 in.). The magnet is 69 cm × 69 cm (27 in. × 27 in.).

A distance of 1 m (3 ft) should be maintained around the standard cabinet. Service requirements for the third rf, imaging, and solids outlets are described in the “Installation Site Preparation” section.

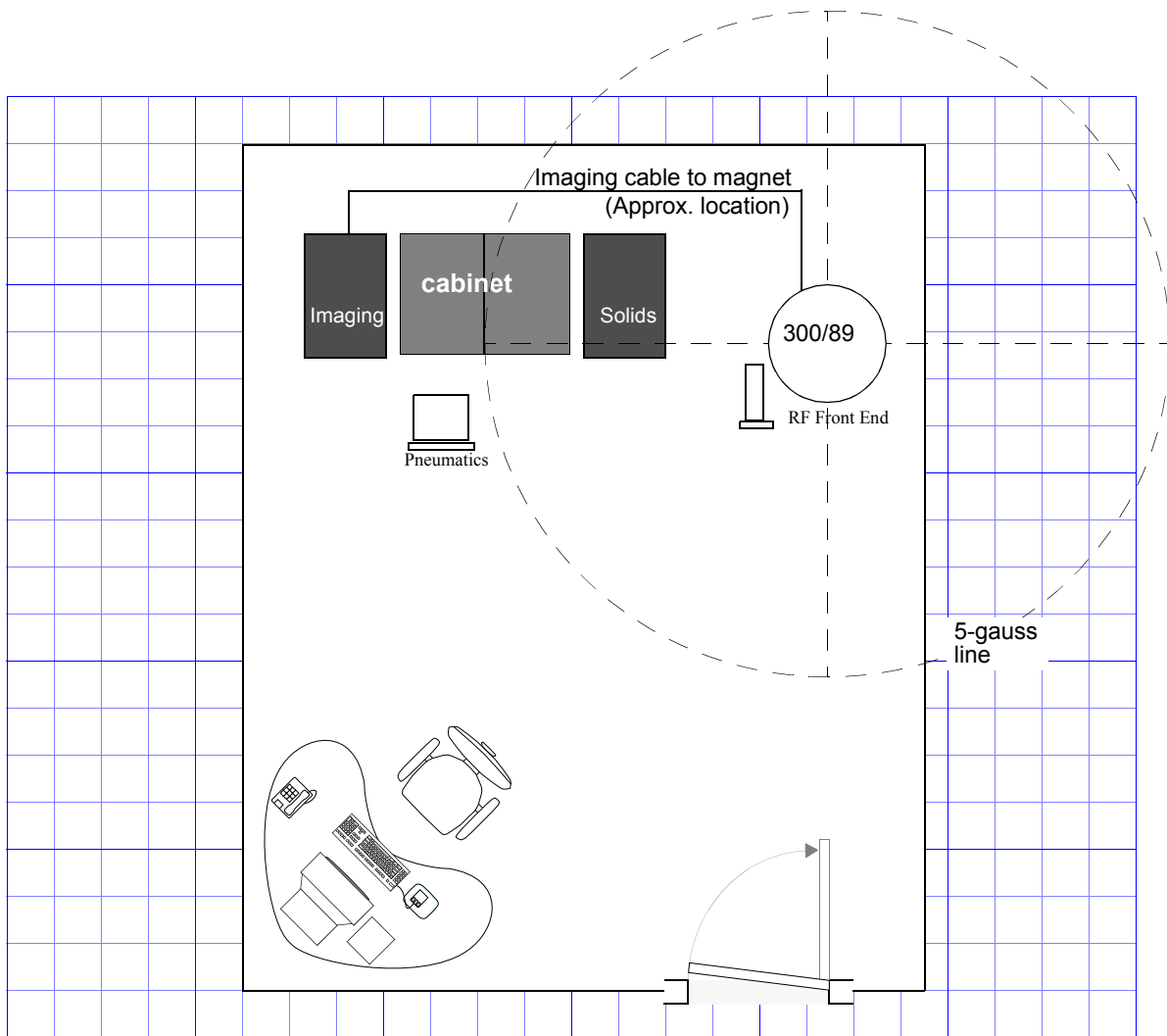



1/4 in. = 1ft

### Standard Space for a 400/54 or 300/89 System Without Options

The room dimensions are about 4.4 m  $\times$  4.6 m (14.5 ft  $\times$  15.2 ft). The cabinet is 111 cm  $\times$  78 cm (44 in.  $\times$  31 in.). Typical table size is 183 cm  $\times$  76 cm (72 in.  $\times$  30 in.). The magnet is 80 cm (32 in.) in diameter.

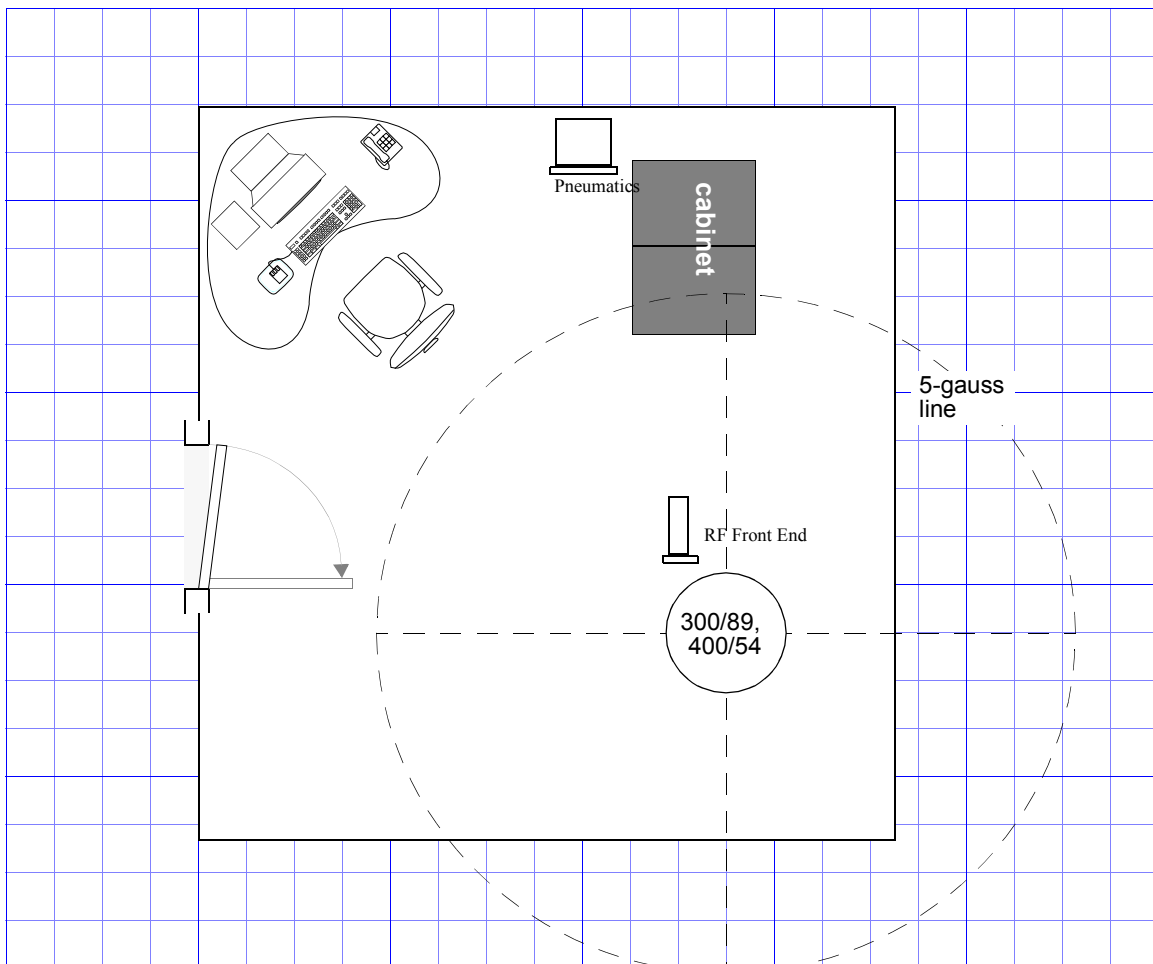
A distance of 1 m (3 ft) should be maintained around the standard cabinet.



  
1/4 in. = 1 ft

### Standard Space for a 400/54 or 500/51 System With Options

The room dimensions are about 5.2 m × 6.7 m (17 ft × 22 ft). The cabinet is 111 cm × 78 cm (44 in. × 31 in.). The imaging and high-power solids cabinets are 55 cm × 78 cm (22 in. × 31 in.) each. Typical table size is 183 cm × 76 cm (72 in. × 30 in.). The magnet is 80 cm (32 in.) in diameter. A distance of 1 m (3 ft) should be maintained around the cabinets. Service requirements for the imaging and solids outlets are described in [Section 3.3, “Electrical Outlets,”](#) on page 38. The SMS table is about 64 cm × 69 cm (25 in. × 35 in.) and should be oriented to the magnet as described in the Sample Management Systems manual.

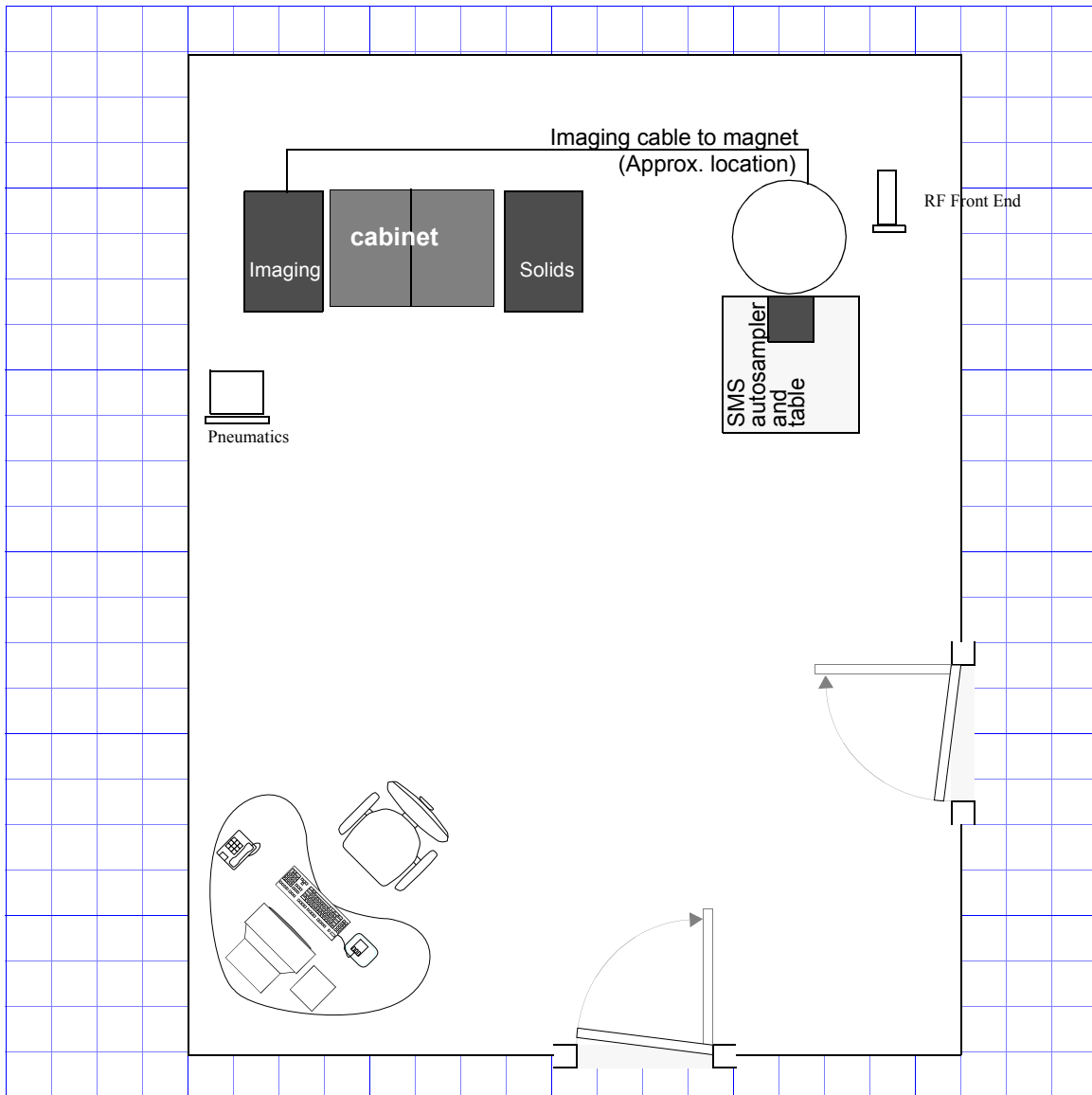

1/4 in. = 1ft

## Minimum Space for a 600/51 System

Room dimensions are about 6.1 m × 6.1 m (20 ft × 20 ft). The cabinet is 111 cm × 78 cm (44 in. × 31 in.). Typical table size is 183 cm × 76 cm (72 in. × 30 in.). The magnet is 97.8 cm (38.5 in.) in diameter.

The magnet should be a minimum of 1.5 m (5 ft) from any wall. A distance of 1 m (3 ft) should be maintained around the cabinets. The service space should be at least 132 cm (52 in.).

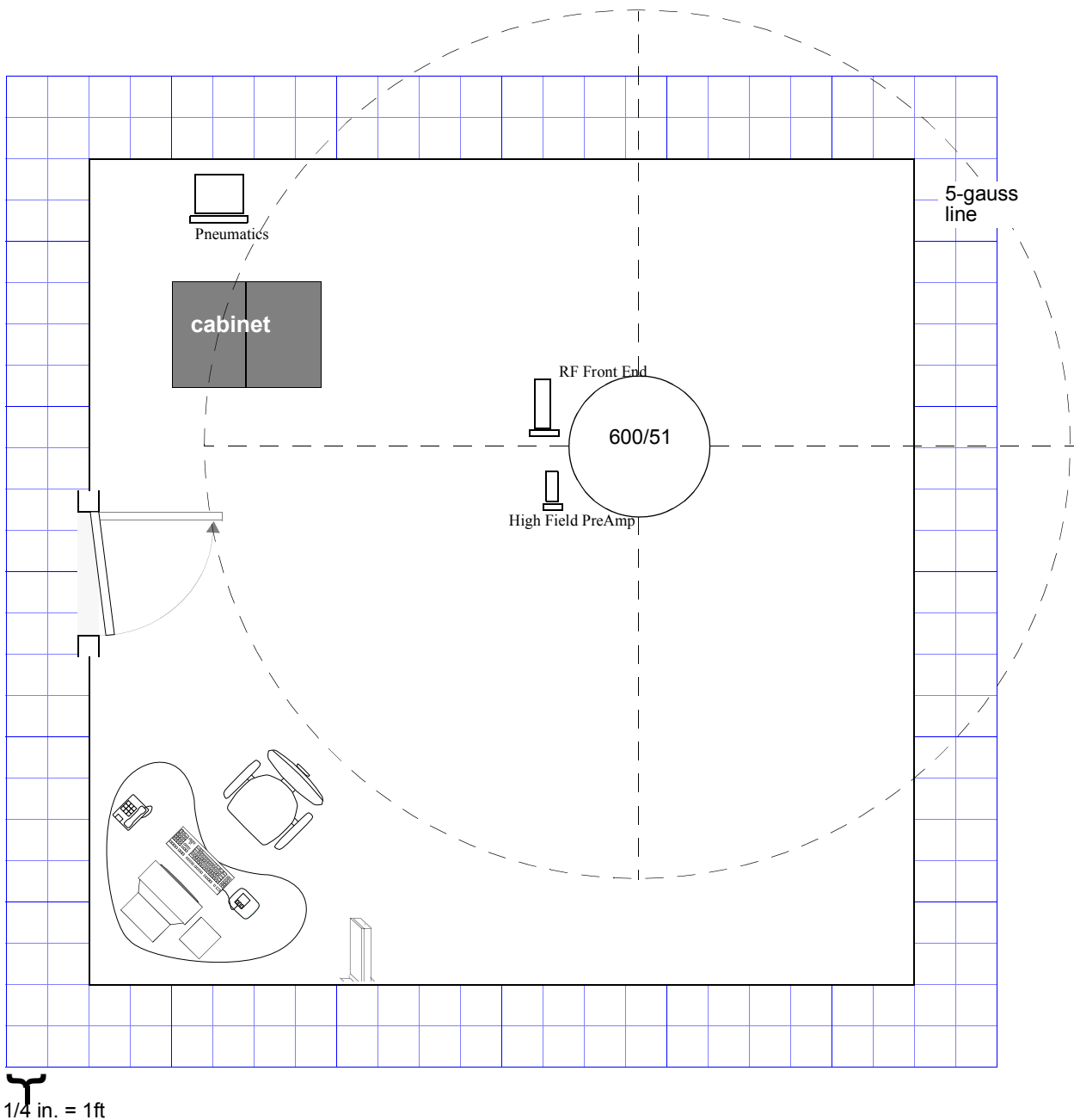

## LC-NMR Minimum Room Layout

Room dimensions are about 6.1 m × 6.1 m (20 ft × 20 ft). The cabinet is 111 cm × 78 cm (44 in. × 31 in.). Typical table size is 183 cm × 76 cm (72 in. × 30 in.). The magnet is 97.8 cm (38.5 in.) in diameter.

- The transfer tube between the LC system and the probe is 15 feet (4.6 meters), no longer. Therefore, the distance between the LC hardware and the magnet should be about 10 feet to accommodate drops and rises.
- The LC STAR workstation (PC) should be set up close to the Sun host computers.
- Cable lengths from the LC STAR workstation (PC)—up to 30 feet between the LC workstation and the LC hardware; up to 40 feet between the LC workstation and the NMR console.

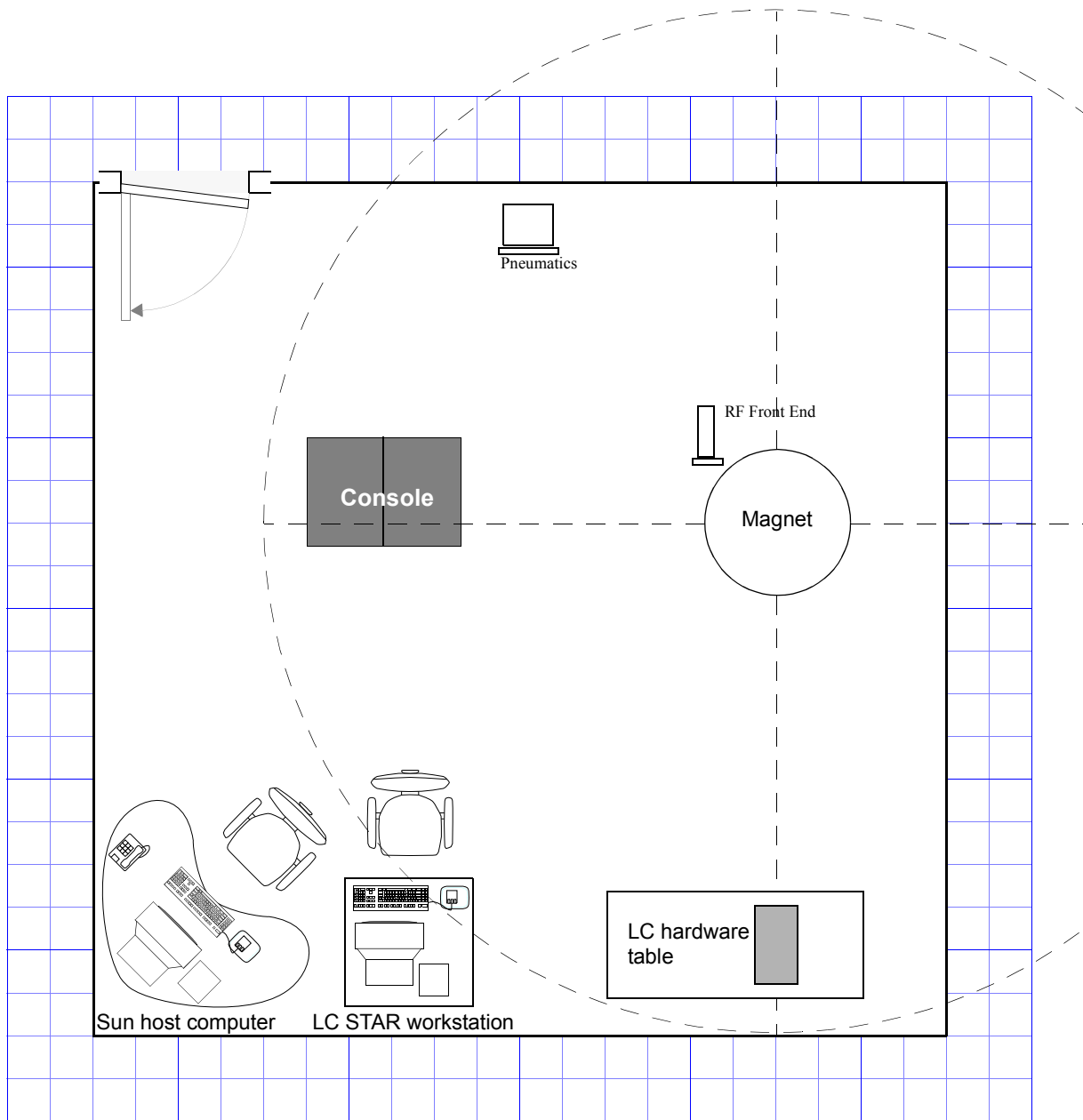

1/4 in. = 1ft

### LC-NMR Suggested Room Layout 1

Room dimensions are about 6.7 m × 7.3 m (22 ft × 24 ft). The cabinet is 111 cm × 78 cm (44 in. × 31 in.). Typical table size is 183 cm × 76 cm (72 in. × 30 in.). The magnet is 97.8 cm (38.5 in.) in diameter.

- The transfer tube between the LC system and the probe is 15 feet (4.6 meters), no longer. Therefore, the distance between the LC hardware and the magnet should be about 10 feet to accommodate drops and rises.
- The LC STAR workstation (PC) should be set up close to the Sun host computers.
- Cable lengths from the LC STAR workstation (PC)—up to 30 feet between the LC workstation and the LC hardware; up to 40 feet between the LC workstation and the NMR console.

### LC-NMR Suggested Room Layout 2

Room dimensions are about 7.3 m × 7.3 m (24 ft × 24 ft). The cabinet is 111 cm × 78 cm (44 in. × 31 in.). Typical table size is 183 cm × 76 cm (72 in. × 30 in.). The magnet is 97.8 cm (38.5 in.) in diameter.

- The transfer tube between the LC system and the probe is 15 feet (4.6 meters), no longer. Therefore, the distance between the LC hardware and the magnet should be about 10 feet to accommodate drops and rises.
- The LC STAR workstation (PC) should be set up close to the Sun host computers.
- Cable lengths from the LC STAR workstation (PC)—up to 30 feet between the LC workstation and the LC hardware; up to 40 feet between the LC workstation and the NMR console.



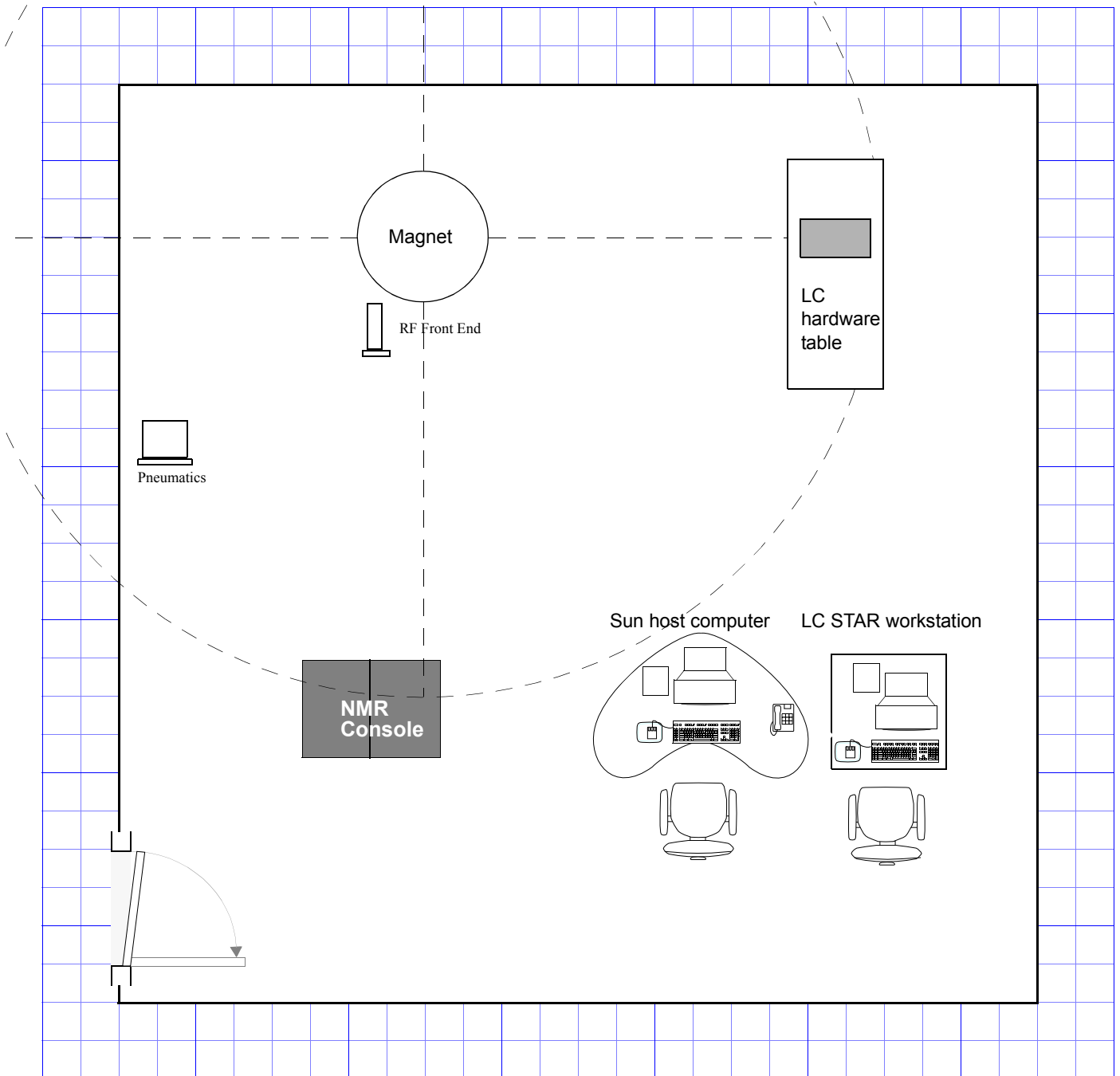

1/4 in. = 1ft

### Illustrations for Room Layout

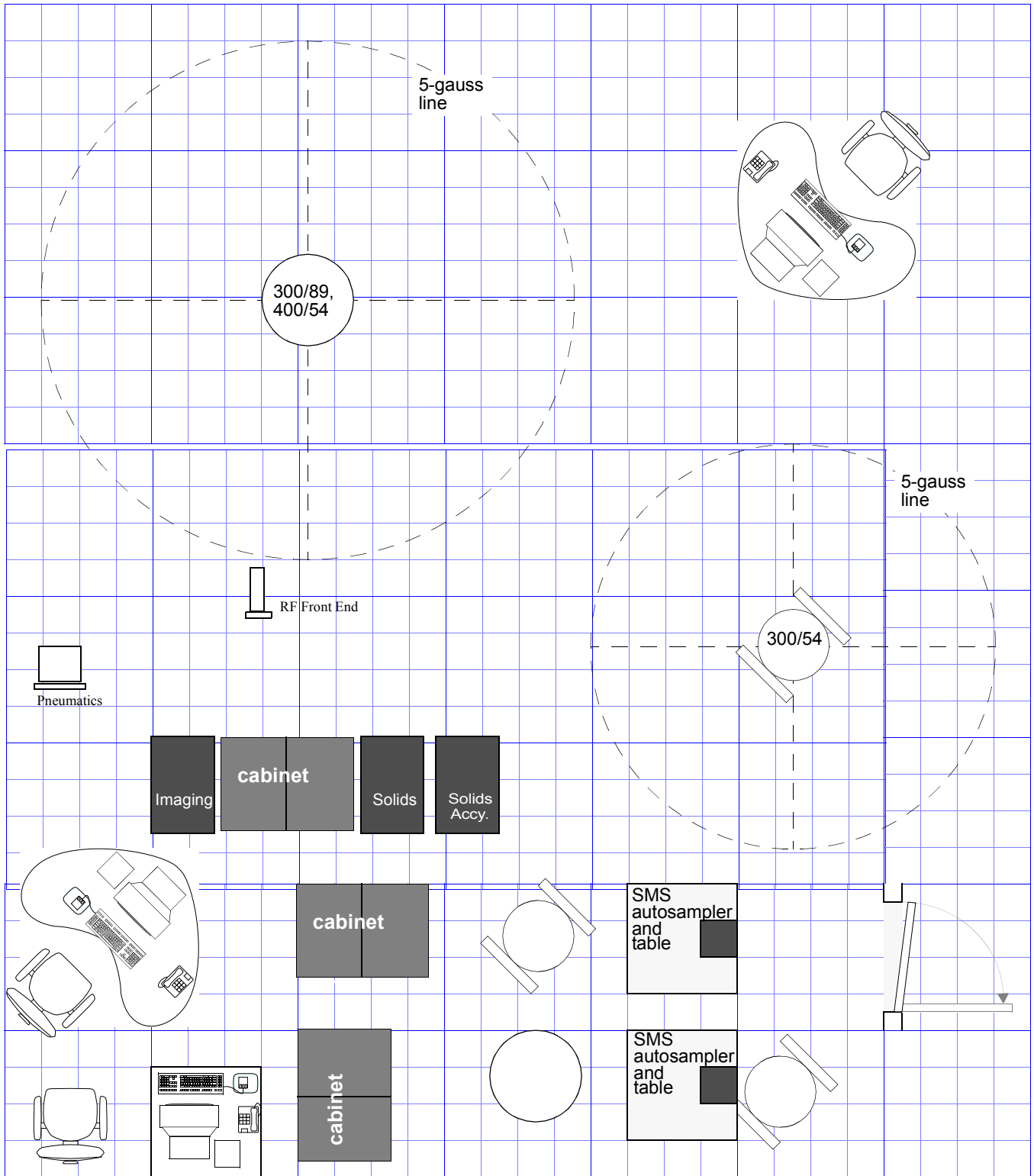

1/4 in. = 1ft

### Blank Grid for Room Layout

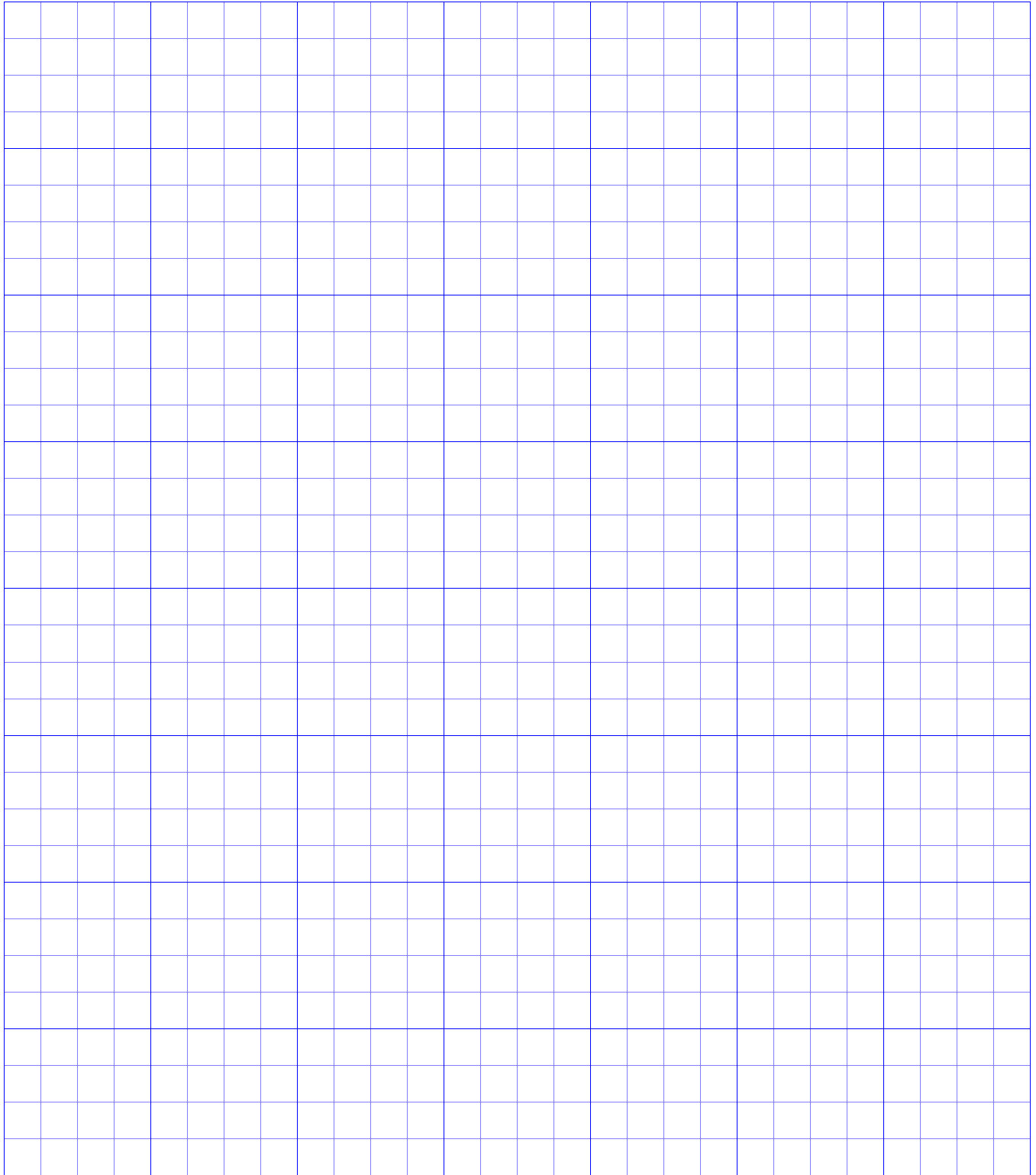

 1/4 in. = 1ft



**A**

ac power  
   line conditioning, 43  
   surge current, 43  
 accessibility of site, 19  
 acetone, 52  
 acetonitrile requirements, 53  
 A-frame for chain hoist, 52  
 air compressor, 42  
 air conditioning requirements, 33, 43  
   additional rf channel, 44  
   air filtration, 43  
   ambient temperature requirements, 32  
   complete solids module, 44  
   CP/MAS option, 44  
   CRAMPS/multipulse module, 44  
   for temperature stability, 32  
   imaging module, 44  
   intake filter, 43  
   Performa XYZ PFG, 44  
   separate power line, 43  
   Solids Accessory cabinet, 44  
   to reduce humidity levels, 32  
   Ultra-nmr shims, 44  
   wideline module, 44  
 air dryer assembly, 42  
 air filter, 42  
 air freight delivery, 20  
 air reservoir, 41  
 air source, separate  
   antivibration legs, 40  
   CP/MAS option, 41  
   CRAMPS option, 41  
   vibration isolation table, 40  
 air supply, main, 41  
   air termination fitting, 42  
   ball valve, 42  
   gate valve, 41  
   high humidity areas, 42  
   prefilter, 42  
 air ventilation, 32  
 ambient humidity, 32  
 ambient temperature, 33  
 antistatic spray, 45  
 antivibration systems, 29  
 ASM-100 sample changer, 39–40  
 automatic teller machine (ATM) cards caution, 11

**B**

ball valve, 42  
 building inspector, 37

**C**

cardiac pacemaker wearers, 55  
 cardiac pacemakers, 55  
 Carousel Autosampler, electrical outlets, 40  
 cautions defined, 9  
 ceiling height, 25  
 centerline to floor distance, 31  
 CFM-rated fans for ventilation, 32  
 chain hoist, 52

codes, 37  
 color CRTs, 30  
 complete solids module  
   air conditioning requirements, 44  
   electrical requirements, 39  
 compressed air supply, 41  
 compressed nitrogen gas  
   flow and pressure rates, 42  
   supply requirements, 42  
   variable temperature accessory, 42  
 compressor, 42  
 computer preparation, 45  
 CP/MAS accessory  
   air conditioning requirements, 44  
   air source requirements, 41  
 CP/MAS Module, electrical outlets, 39  
 CRAMPS/multipulse  
   air conditioning requirements, 44  
 crate unpacking, 21  
 credit cards caution, 11  
 cryogen equipment, 53  
 cryogen warning, 52  
 cryogenic equipment rack, 53

**D**

dataless client, 47  
 degaussing coil, 53  
 delivery of supplies, 23  
 delivery responsibility, 17  
 delivery services, 20  
 Diffusion Accessory, electrical outlets, 40  
 domain name, 48  
 domainname command, 48  
 Doty probe  
   compressed air supply source, 41

**E**

electrical grounds, 39  
 electrical outlet requirements, 38  
   4-channel system, 39  
   5 or more channels, 39  
   750/51 third cabinet, 39  
   diffusion accessories, 40  
   host computer and peripherals, 39  
   LC-NMR accessory, 40  
   microimaging module, 39  
   PFG accessories, 40  
   Pneumatics Router, 39  
   separate ground for third cabinet, 39  
   SMS autosampler system, 40  
   solid-state power cabinets (channels 1 & 2/  
     channels 3 & 4), 39  
   standard two-cabinet console, 39  
   test equipment outlets, 40  
   VAST autosampler system, 40  
   VT CP/MAS, 39  
 electrical power surge protector, 53  
 electrostatic discharge, 45  
   antistatic spray, 45  
   carpeting requirements, 45  
   caution, 45  
   floor coverings, 45

## Index

- grounding, 45
- preventing, 45
- equipment rack, 53
- expansion ratio of liquid helium, 32

## F

- face mask, 52
- fans for ventilation, 32
- flammable gases warning, 10
- floor structure strength, 26
- floor vibration, measurement, 29
- flutter tube, 53
- FOB block, 21
- frequencies
  - for common nuclei, 34
  - ranges, 33

## G

- gate valve, 41
- gauss levels, 57
- G-force indicator, 19, 21
- gHX Nano probe, 41
- gradient power cabinet, 39
- Granite vibration isolator, 19

## H

- heat gun, 52
- helium contact with body, 10
- helium gas flowmeters caution, 12
- helium gas supply, 51
  - cylinder requirements, 51
  - magnetic helium gas container, 51
  - purity requirements, 51
- helium supplies, 49
- helium, liquid expansion ratio, 32
- high altitudes sites, 33
- Highland L500, 39
- high-power amplifiers cautions, 12
- hoist, 52
- hoist clearance, 19
- holding tank, 42
- host name, 47
- host workstation
  - magnetic field considerations, 45
- host workstation, electrical outlets, 39
- humidity levels for a site, 32

## I

- installation department, 21
- installation equipment, 49
- installation site preparation, 37
- installation site requirements, 23
- installation supplies, 49
- interference, radio frequency, 33
- interference, rf, 33
- Internet Protocol network address, 47
- IP address, 47
- isopropyl alcohol, 52

## L

- laboratory size requirements, 23
- ladder, 52
- LC STAR workstation, 82–83
- LC-NMR accessory
  - acetone-d6 requirements, 53
  - acetonitrile requirements, 53
  - D2O requirements, 53
  - electrical outlet requirements, 40
  - helium requirements, 53
  - minimum room layout, 82
  - nonmagnetic table, 53
  - preinstallation supplies, 53
  - suggested room layout, 83
  - suggested room layout 2, 83
  - transfer tube length, 82–83
- lifting equipment, 19
- line conditioner, 38
- line conditioning, 43
- line voltage variation, 37
- liquid helium
  - boiloff, 50
  - caution about dewars, 50
  - expansion ratio, 32
  - flexible transfer tube, 50
  - for 200/54 or 300/54 magnets, 50
  - initial supply, 50
  - locate a reliable source, 49
  - rigid transfer tube, 50
  - supply, 50
  - supply dewars, 50
- liquid nitrogen
  - adaptor for rubber tubing, 51
  - boiloff, 51
  - locate a reliable source, 49
  - recommended quantities, 51
  - storage containers, 51
  - supply requirements, 51
  - VT accessory operation, 51
  - VT cooling bucket, 51
- LPM-rated fans for ventilation, 32

## M

- magnet crate, 19, 21
- magnet field homogeneity, 30
- magnet quench warning, 10
- magnet tipping hazard, 29
- magnet transport, 21
- magnetic environment, 30
- magnetic field considerations for computers, 45
- magnetic field exposure, 56
  - cardiac pacemakers, 55
  - effects on equipment, 30
  - reproductive hazard, 56
  - risk to pregnancy, 56
  - storage media, 45
  - stray field data, 56
- magnetic field plots, 57
- magnetic field profiles, 30
- magnetic field warning signs, 71
- magnetic interference, 25, 30
- magnetic media caution, 11

- metal objects warning, 9
- microimaging module
  - air conditioning requirements, 44
  - compressed air supply source, 41
- Microimaging Module, electrical outlets, 39
- modifying the instrument, 10
- monitor degaussing coil, 53
- moving crates, 17, 21
- moving equipment, 21
- moving van delivery, 20
- multipulse
  - air conditioning requirements, 44

## N

- name service, 48
- Nano probe, 41
- NFS server, 47
- NIS or NIS+ server, 48
- nitrogen contact with body, 10
- nitrogen gas flowmeters caution, 12
- nitrogen gas requirements, 42
- nitrogen gas supply
  - low-temperature operation requirements, 51
  - magnetic nitrogen gas container, 51
  - precooling requirements, 51
  - purity requirements, 51
  - VT accessory, 51
- nitrogen supplies, 49
- NMR work table, 19

## O

- Object Code License Form, 17
- oil filter, 42
- opening crates, 21
- operating frequencies, 34
- operating frequency, 33
- Order Acknowledgment form, 17, 21

## P

- pacemaker warning, 9
- pacemakers, 55
- PDU, 39
- Performa XYZ PFG
  - air conditioning requirements, 44
- PFG Accessories, electrical outlets, 40
- Pneumatics Router
  - electrical outlet requirements, 39
- postdelivery instructions, 21
- posting requirements, 71
- power conditioning system, 38
- power distribution unit, 39
- power line analyzer, 37
- power outages, frequent and short, 38
- power stick, 25
- power supplies, uninterrupted, 38
- pregnancy hazard, 56
- pressure gauge, 42
- primary air regulator, 41
- prosthetic parts warning, 9

## Q

- quench, 32

## R

- radio-frequency (rf)
  - interference, 33
- radio-frequency emission regulations, 12
- receiving preparations, 20
- reduction valve, 42
- relief valves warning, 11
- removable quench tubes warning, 11
- reproductive hazard, 56
- reservoir for air, 41
- rf channel additional
  - air conditioning requirements, 44
- rf emissions from Varian NMR, 34
- rf interference, 25, 33
- rf tests, 34
- rfl, 33
- room layouts, 73

## S

- safety precautions, 9, 11
- sales centers, 14
- scheduling installation, 21
- server, 47
- service centers, 14
- Ship By date, 17
- shipping crate damage, 21
- shipping method, 20
- signs, 71
- site accessibility, 19
- site size requirements, 23
- site survey, 17
- size of site, 23
- SMS Autosampler
  - air conditioning requirements, 44
- SMS Autosampler robot, 19
- SMS Autosampler table, 19
- SMS Autosampler, electrical outlets, 40
- Solids Accessory cabinet, 19
  - air conditioning requirements, 44
- solids high-power amplifiers caution, 12
- Solid-State Accessories Cabinet, electrical outlets, 39
- Solid-State Power Cabinets, electrical outlets, 39
- solvents, 52
- spectrometer frequency ranges, 33
- stand alone, 47
- step-down transformer, 39
- stingers, 53
- stray field plots, 31, 55, 57
- streaming tape cartridge, 45
- structural floor loading rating, 26
- subnet mask, 47
- sucrose requirements, 53
- Sun peripherals, 45
- sunlight, 32
- supplies, 49
- supply dewars, 23
- supporting the magnet, 29

## Index

surge current, 43  
surge protection, 39, 53

## T

temperature stability, 32  
thermal gloves, 52  
third rf channel  
    compressed air supply source, 41  
tip-and-tell indicator, 19, 21  
transfer of ownership, 21  
transfer tube, 25, 53  
Tygon tubing, 53

## U

Ultra•nmr shims  
    air conditioning requirements, 44  
uname -n command, 47  
uncrating system, 19  
upper barrel warning, 10  
UPS systems, 38

## V

van delivery, 20  
Varian sales and service centers, 14  
VAST Autosampler, electrical outlets, 40  
ventilation, 32  
vertical magnetic fields, 30  
vibration in floor, 29  
vibration in floor, measurement, 29  
vibration table, 40  
voltage variations, 37  
volumetric flasks requirements, 53  
VT CP/MAS Module, electrical outlets, 39  
VT experiment warning, 10

## W

warning signs, 71  
warnings defined, 9  
waste container, 53  
waste container cover, 53  
wideline module  
    air conditioning requirements, 44  
    compressed air supply source, 41  
workstation preparation, 45

## Y

ypcat command, 47  
ypwhich command, 48